



Operating instructions

Last updated: 01.2015

Motor unit for hinged gates

Comfort 585, 586

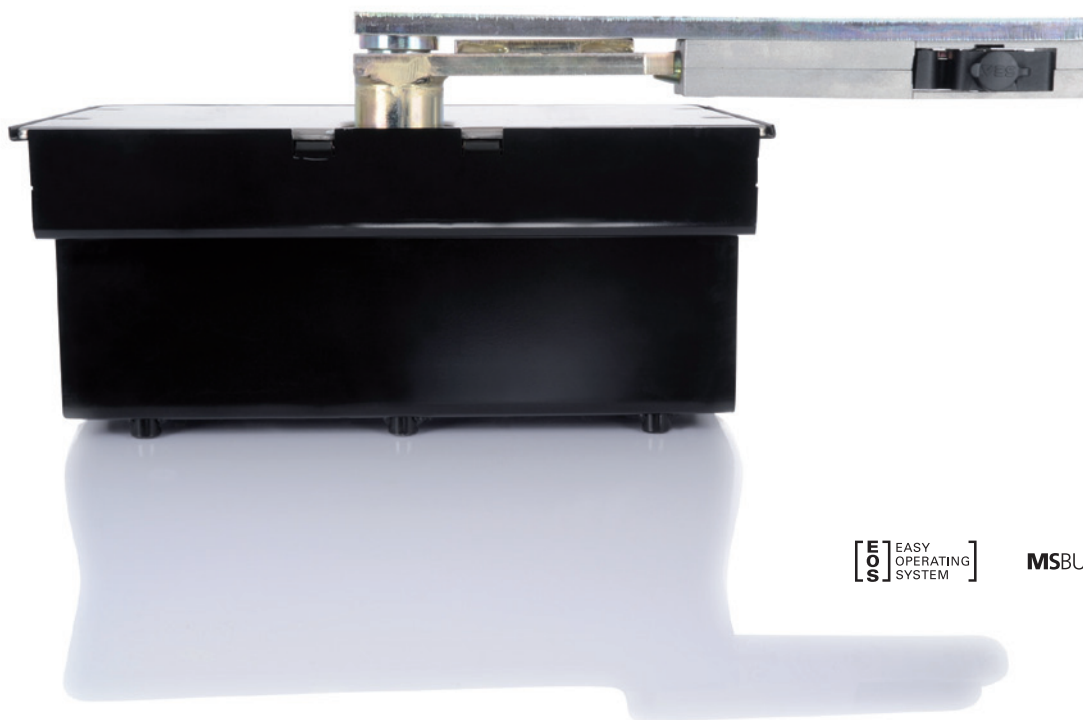

[E] EASY
[O] OPERATING
[S] SYSTEM

MSBUS 

Table of Contents

1.	General safety instructions	3
1.1	Intended use	3
1.2	Target group	3
1.3	Warranty	3
2.	Scope of supply	4
3.	Gate system	4
4.	Installation	5
4.1	Preparing for installation	5
4.2	Foundation layout	6
4.3	Installing the operator housing	6
4.4	Installing the gate wing	8
4.5	Installing the motor unit	9
4.6	Installing the release mechanism	9
4.7	Fitting the limit stops	10
4.8	Fitting the reference point sensor	10
4.9	Setting the limit stops	10
4.10	Completing the installation	11
4.11	Connecting to the junction box	11
4.12	Connection to the control unit	12
5.	Operation	12
5.1	Hand transmitter	12
5.2	Release mechanism	12
6.	Maintenance	12
7.	Disassembly	13
8.	Disposal	13
9.	Rectifying faults	13
10.	Appendix	13
10.1	Technical data	13
10.2	Declaration of Incorporation	14

DANGER!

IMPORTANT SAFETY INSTRUCTIONS:

ATTENTION! IT IS VITALLY IMPORTANT FOR THE SAFETY OF PERSONS THAT YOU FOLLOW ALL THE INSTRUCTIONS. KEEP THESE INSTRUCTIONS IN A SAFE PLACE.

IMPORTANT INSTRUCTIONS FOR SAFE INSTALLATION:

ATTENTION! SERIOUS INJURIES CAN BE CAUSED IF THE EQUIPMENT IS NOT INSTALLED CORRECTLY – BE SURE TO FOLLOW ALL THE INSTALLATION INSTRUCTIONS.

Regarding this document

- Original instruction manual.
- Part of the product.
- Read these instructions carefully before use and keep them in a safe place for future reference.
- Protected by copyright.
- No part of this manual may be reproduced without our prior approval.
- Subject to alterations in the interest of technical progress.
- All dimensions are given in millimetres.
- The drawings are not true to scale.

Meaning of symbols

DANGER!

Safety notice indicating a danger that will directly result in death or severe injury.

WARNING!

Safety notice indicating a danger that could result in death or severe injury.

CAUTION!

Safety notice indicating a danger that could result in slight or moderate injuries.

NOTICE

Safety notice indicating a danger that could result in damage to property or irreparable damage to the product.

CHECK

Reference to a check that needs to be carried out.

REFERENCE

Reference to separate documents that must be observed.

- Instruction requiring action
- List, itemisation
- Reference to other sections of this document
-  Factory settings

1. General safety instructions

DANGER!

Failure to comply with the documentation could result in life-threatening danger!

- Be sure to follow all the safety instructions in this document.

1.1 Intended use

- The operator system is designed exclusively for opening and closing gates.
- Never use the gate to lift persons or objects.

The following applies for the product Comfort 585, 586:

- The following data must be complied with:
 - Maximum pulling force
 - Maximum compressive force
 - Maximum gate size
 - Maximum gate weight
- "10.1 Technical data"
- This product is intended for residential use.
- This product is only suitable for hinged gates.
- The motor unit requires a suitable control unit for operation.

1.2 Target group

- Installation, connection and setting in operation:
Qualified, trained skilled personnel.
- Operation, inspection and servicing:
The operator of the gate system.

Requirements to be met by qualified and trained skilled personnel:

- Knowledge of the general and specific safety and accident prevention regulations.
- Knowledge of the relevant electrical regulations.
- Training in the use and care of appropriate safety equipment.
- Adequate instruction and supervision by qualified electricians.
- The ability to recognise hazards that can be caused by electricity.
- Knowledge of the application of the following standards
 - EN 12635 ("Doors and gates - Installation and use"),
 - EN 12453 ("Safety in use of power operated doors - Requirements"),
 - EN 12445 ("Safety in use of power operated doors - Test methods"),

Requirements to be met by the operator of the gate system:

- Knowledge and safekeeping of the instruction manual.
- Knowledge of the relevant general safety and accident prevention regulations.

Special requirements apply to the following users:

- Children aged eight and above.
- Persons with reduced physical, sensory or mental capabilities.
- Persons with a lack of experience and knowledge.

These users may be involved only in operation and maintenance.

Special requirements:

- The users must be supervised.
- The users must have been briefed on how to use the device.
- The users must understand the dangers involved in handling the device.
- Children are not allowed to play with the device.

1.3 Warranty

The product is manufactured in accordance with the directives and standards listed in the manufacturer's declaration and in the declaration of conformity.

The product left the factory in perfect working order.

In the following cases, the manufacturer will accept no liability for damage. The warranty for the product and accessory components becomes void in the event of:

- Failure to observe these operating instructions.
- Incorrect handling and use of the product for anything other than its intended purpose.
- Work being carried out by unqualified personnel.
- Changes or modifications to the product.
- The use of replacement parts that have not been approved or were not manufactured by the manufacturer.

The warranty does not cover batteries, rechargeable batteries, fuses and bulbs.

Further safety instructions are given in the relevant sections of this document.

- "4. Installation"
- "6. Maintenance"
- "7. Disassembly"

2. Scope of supply

The Comfort 586 / 586 can be supplied in the following versions, as required:

Single wing gate system:

- Comfort 585 / 586, 1x motor unit

Double wing gate system:

- Comfort 585 / 586, 2x motor unit

The supply package includes

- Operator housing
- Housing cover
- Electric motor
- Crankset
- Wing device
- Connecting rod
- Adjustable limit stop in CLOSING direction
- Adjustable limit stop in OPEN direction
- Fixing materials for cover and limit stops
- Grease, type A (water-repellent)
- Emergency release mechanism
- Junction box with terminal strip

The scope of supply is doubled in the case of double wing gate versions.

Overview of components

2 / 1

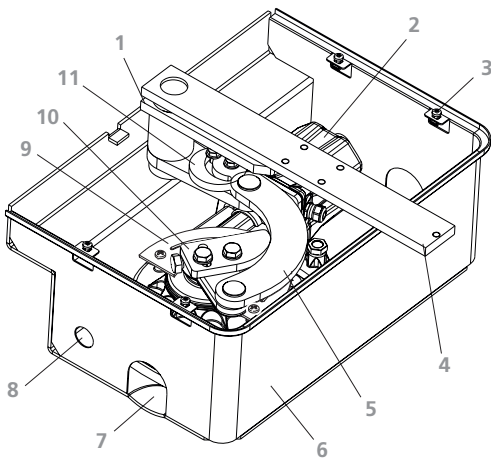

Comfort 585 / 586 (assembled, without housing cover)

- 1 Crankset
- 2 Electric motor
- 3 Cover fixing screws
- 4 Wing device
- 5 Connecting rod
- 6 Operator housing
- 7 Water drain hole
- 8 Cable opening
- 9 Support plate for reference point sensor
- 10 Adjustable limit stop in CLOSING direction
- 11 Adjustable limit stop in OPEN direction

3. Gate system

3 / 1

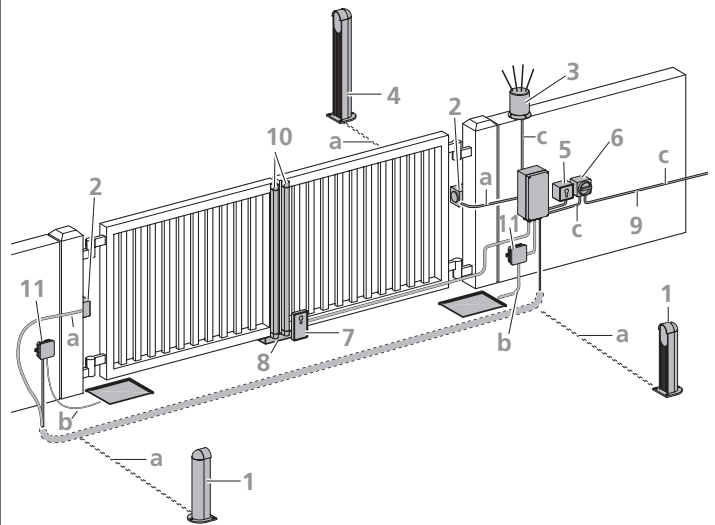

This is just an example of a gate system and can vary depending on the type of gate and the associated equipment. The gate system shown comprises the following components:

- 1 Photocell
- 2 Photocell
- 3 Signal light
- 4 Key switch post (for code button, transponder, ...)
- 5 Wrench
- 6 Main switch (mains isolator switch)
- 7 Electric lock
- 8 Ground stop
- 9 Mains cable
- 10 Closing edge safety device (CESD)
- 11 Junction box with terminal strip

Cable cross-sections:

- a 2 x 0.5 mm²
- b 6 x 0.75 mm²
- c 3 x 1.5 mm²
- d 2 x 0.75 mm²

➡ REFERENCE

For the installation and cabling of the gate sensors, control elements and safety equipment, the relevant installation instructions must be observed.

4. Installation

DANGER!

Life-threatening danger due to electric shock!

- It is vital that you disconnect the operator system from the power supply before commencing cabling work. Take measures to ensure that the power supply remains disconnected for the duration of the cabling work.
- Observe the local safety regulations.
- It is imperative that you lay power cables separately from control cables.
The control voltage is 24V DC.

NOTICE

Material damage resulting from incorrect installation of the operator!

To avoid installation errors and damage to the gate and operator system, the following installation instructions must be observed at all costs.

- Ensure that the gate is in good mechanical order:
 - The gate can be moved easily.
 - The gate opens and closes properly.
- Only use fixing materials that are suitable for the foundation material in question.

4.1 Preparing for installation

Before commencing installation, the following works must be carried out without fail.

Foundations

- Check the proposed position of the foundation.

Scope of supply

- Check that all the parts are present.
- Check that all the necessary accessory parts for your installation situation are present.

Gate system

- Ensure that your gate system structure is sufficiently stable to allow for automation.
- Ensure that the gate can be easily moved by hand.
- Ensure that there are no obstructions in the path of movement of the gate.
- Disassemble the gate latches or render them inoperable.
- Make sure that the size of the top gate hinge is sufficiently large for automatic gate operation.
- Remove all other hinges.
- Ensure that a suitable mains connection and a mains isolator switch are available for your gate system.
The minimum cross-section of the earth cable must be $3 \times 1.5 \text{ mm}^2$.
- Ensure that all cables are suitable for outdoor use with respect to UV resistance and cold resistance.
- Ensure that a suitable control unit is available for your gate system.
- In double wing gate systems, ensure that a cable connection is available from the second motor unit to the control.
The minimum cross-section of this cable must be $6 \times 0.75 \text{ mm}^2$.
- Observe the following gate requirements:
→ "10.1 Technical data"

The use of a mechanical ground stop in the CLOSED gate position is recommended if the gate wing measures 1.8 metres or more.
For gate wing widths of 2 metres or more, the use of an electric lock is recommended.

REFERENCE

When using and installing accessory equipment, observe the corresponding documentation.

4.2 Foundation layout

NOTICE

Material damage resulting from incorrect installation of the operator!

- Ensure that the size of the foundation is adhered to and that a suitable recess is prepared.
- Make sure there is a minimum distance of 47 mm between the axis of rotation and the post.
- Ensure that a PVC water drainage pipe (E) (at least \varnothing 40 mm) is connected to opening (A) on the operator housing and to the drainage system.
- Make sure that an empty conduit (at least \varnothing 30 mm) for electrical cabling is connected to opening (B) on the operator housing and to the corresponding junction box (C).
- Ensure that the operator housing is inserted in the centre of the foundation.
- Check to ensure that the distance between the housing cover and the lower edge of the gate is 64 mm.
- Ensure that the foundation extends below the frost depth (> 800 mm).

4.2 / 1

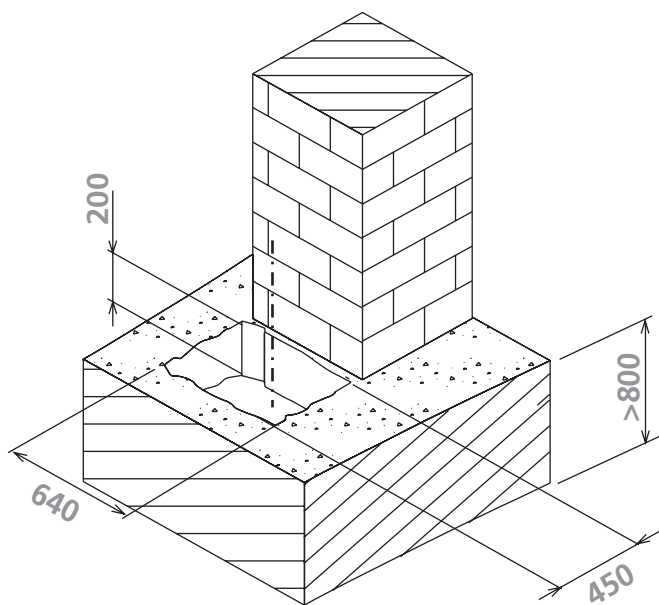

4.2 / 2

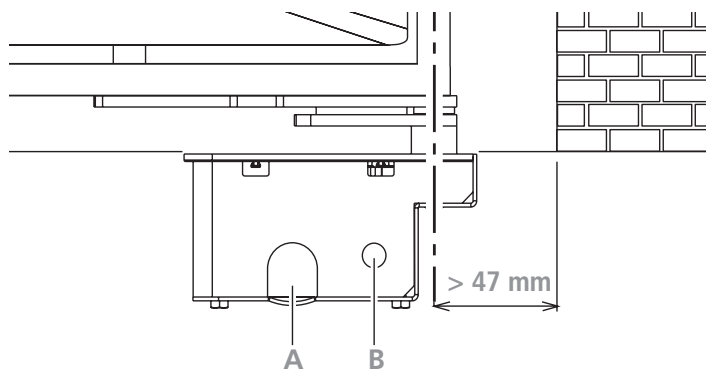

4.2 / 3

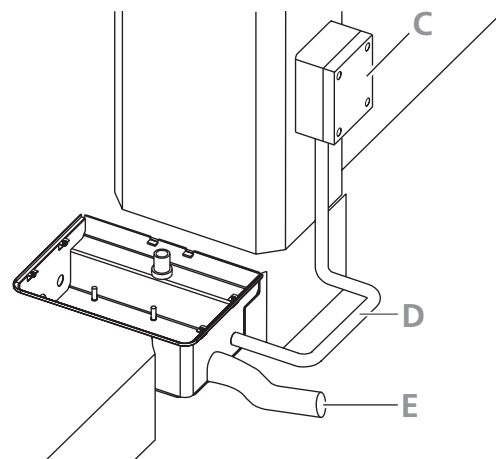

4.2 / 4

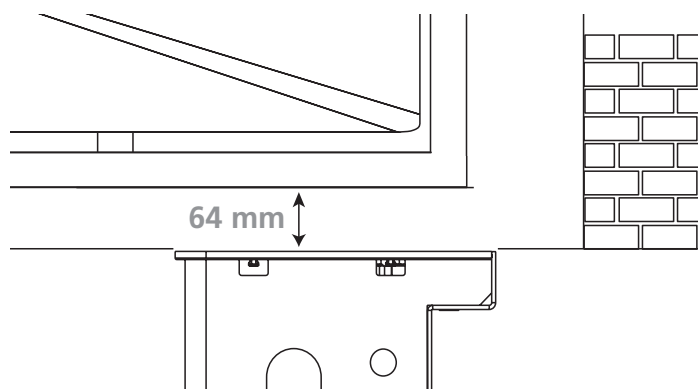

4.3 Installing the operator housing

4.3 / 1

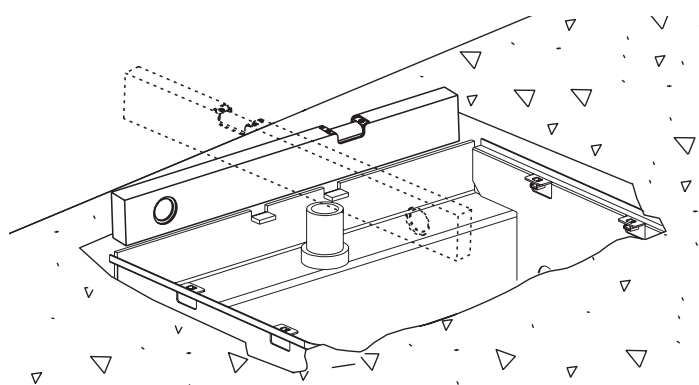

- Place the operator housing in the prepared opening.

4.3 / 2

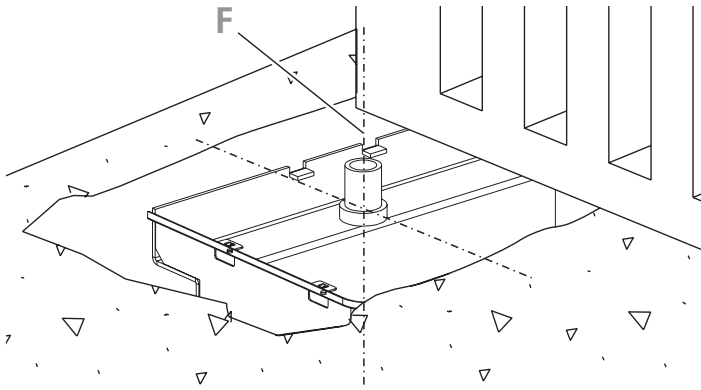

- Align the operator housing so that it is perpendicular to the axis of rotation (F) of the gate hinge.
- Observe the specified installation conditions.
- Check to ensure that the distance between the housing cover and the lower edge of the gate is 64 mm.

→ "4.2 / 4"

- Use self-adhesive tape to seal any holes in the operator housing that are not required.
- Close the operator housing with the cover plate.
- Seal the cover plate using self-adhesive tape.
- Fill in the space surrounding the operator housing with concrete.

NOTICE

Material damage resulting from incorrect installation of the operator!

- Ensure that the operator housing does not change its position during the concreting work.
- Check that the operator housing is horizontal.
- Allow the foundation concrete to fully set.
- Remove the self-adhesive tape and the cover plate.

4.3 / 3

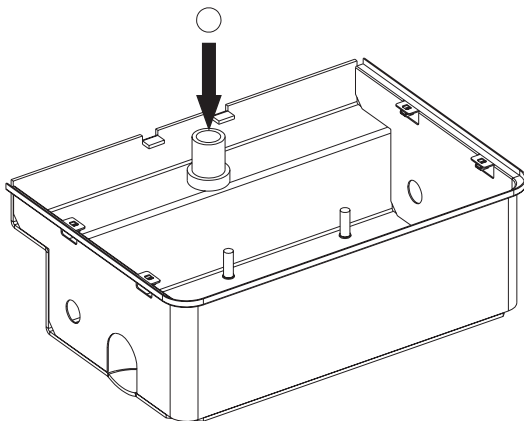

- Lubricate the opening of the hollow shaft and the ball with grease (type A).
- Place the ball in the hollow shaft.

4.3 / 4

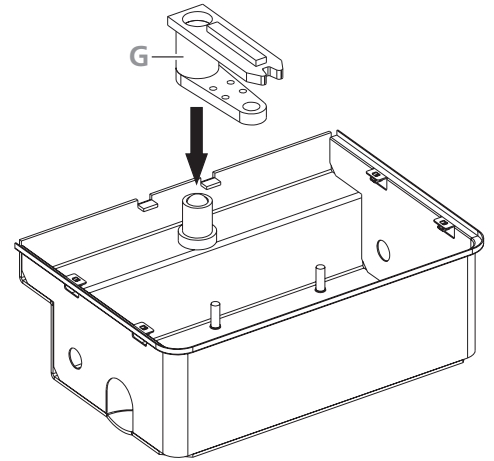

- Lubricate the crankset (G) with grease (type A).
- Attach the crankset to the hollow shaft.

4.3 / 5

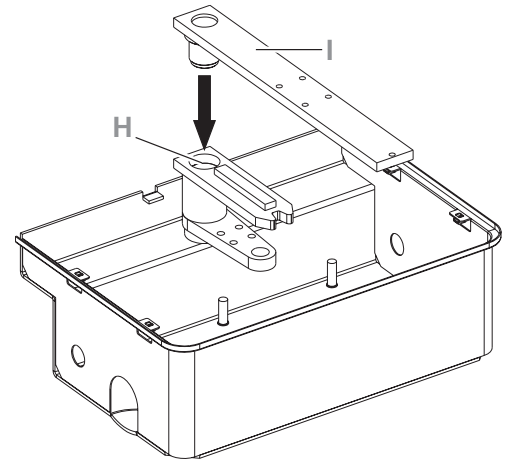

- Lubricate the drill-hole (H) with grease (type A).
- Lubricate the wing device (I) with grease (type A).
- Insert the wing device into the drill-hole (H).

4.3 / 6

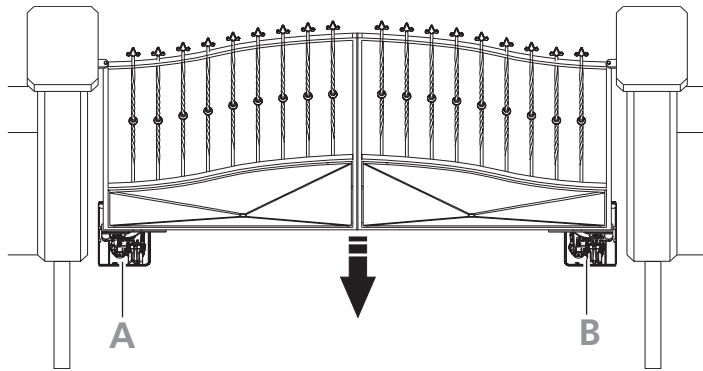

A

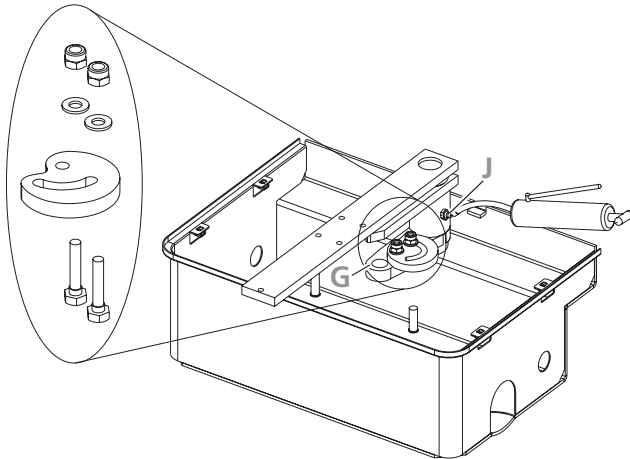

B

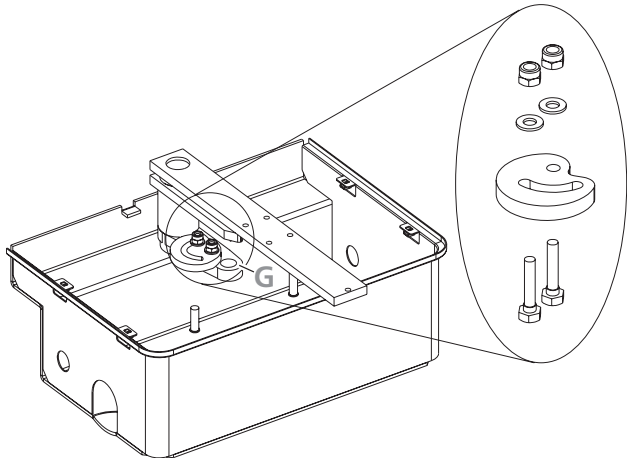

- Place the limit stop cams in the crankset (G).
- Attach the limit stop cams with the appropriate bolts.
- Lubricate the wing device through the lubricating nipple (J) until grease escapes on both sides (grease DIN 51502 KP 2 N - K 2 K-20, not included in the scope of supply).

4.4 Installing the gate wing

✓ CHECK

- Check that the foundation is fully set.

4.4 / 1

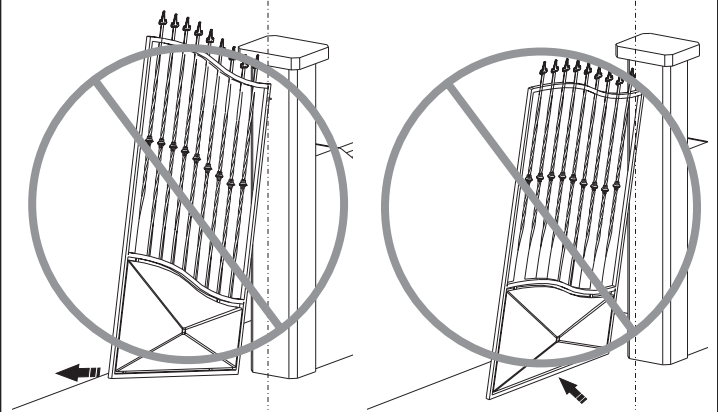

- Ensure that the axis of rotation of the gate hinge is aligned with the pivot point of the wing device.
- Check to ensure that the distance between the housing cover and the lower edge of the gate is 64 mm.

→ "4.2 / 4"

4.4 / 2

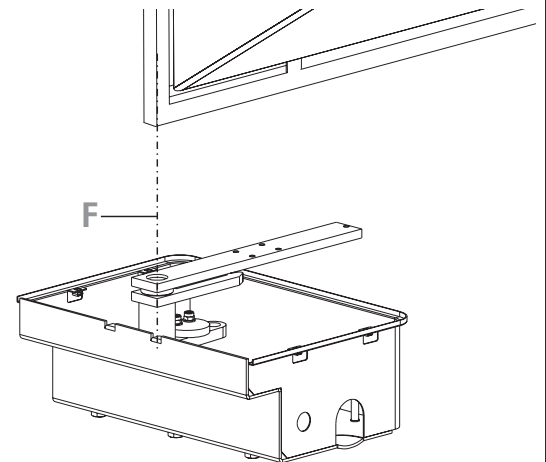

- Position the gate wing on the wing device.
- Pay particular attention to the axis of rotation (F) of the gate wing hinge.

👉 NOTICE

Material damage due to welding!

- Weld the contact surface with 3-4 cm long welding seams.
- Do not weld in the vicinity of drill-holes.

4.4 / 3

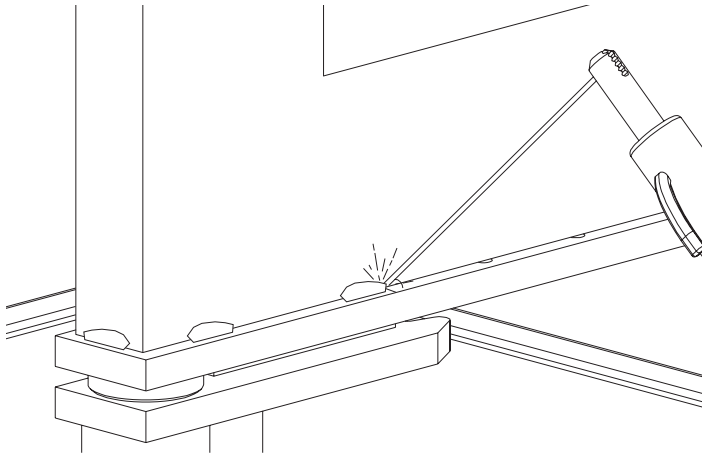

- Weld the wing device to the gate wing.

4.5 Installing the motor unit

4.5 / 1

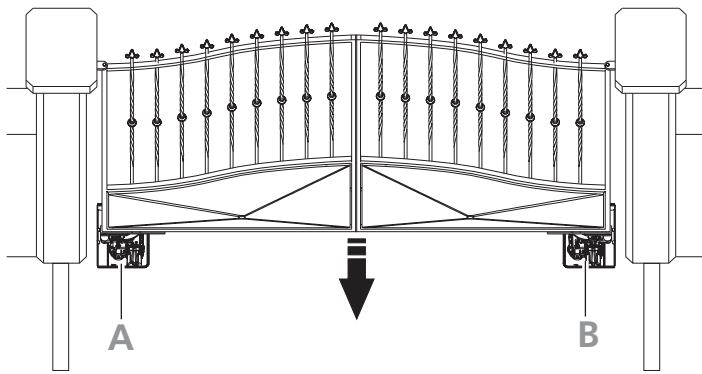

- Allocate the motors to the gate sides so that the motors are facing the direction of opening.

4.5 / 2

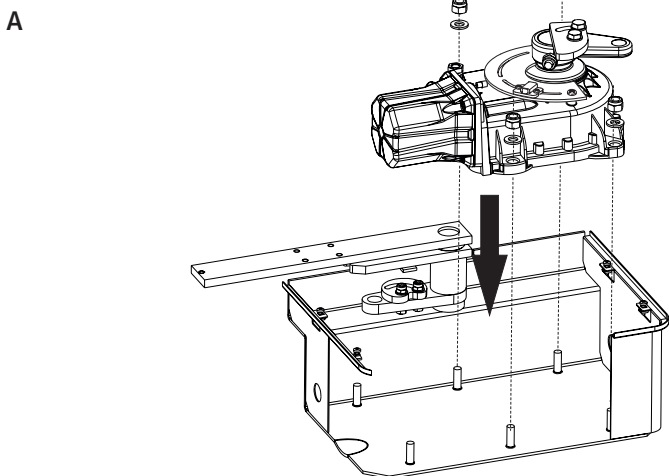

B

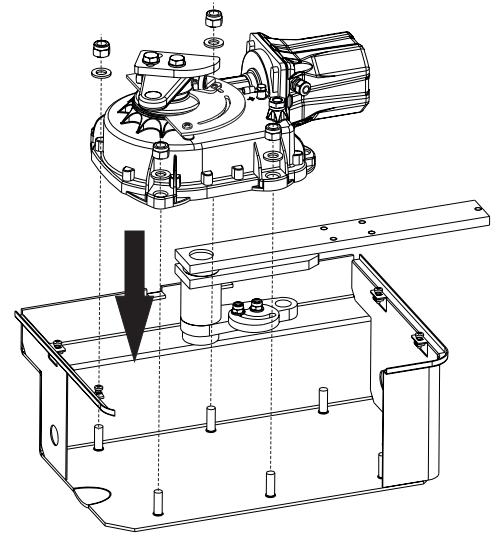

- Place the operator in the operator housing.
- Attach the operator inside the operator housing.

4.5 / 3

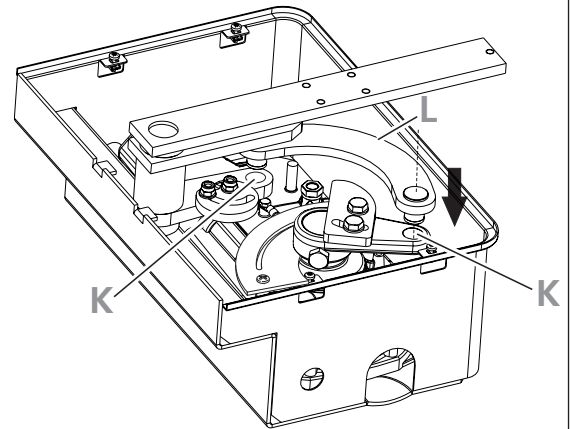

- Lubricate the drill-holes (K) for the connecting rod (L) with grease (type A).
- Connect the crankset and the motor with the connecting rod (L).

4.6 Installing the release mechanism

4.6 / 1

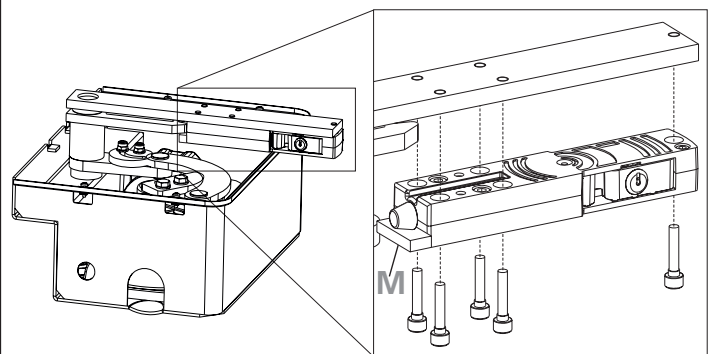

- Lubricate the dowel pin (M) with grease (type A).
- Attach the release mechanism under the wing device.

4.7 Fitting the limit stops

- Close the wing of the gate.

4.7 / 1

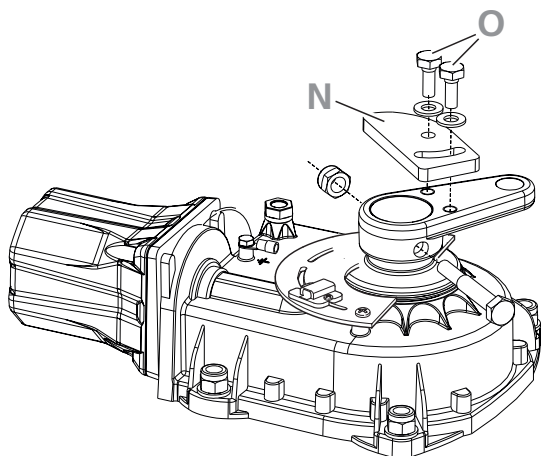

- Fit the limit stop cam (N).

4.8 Fitting the reference point sensor

4.8 / 1

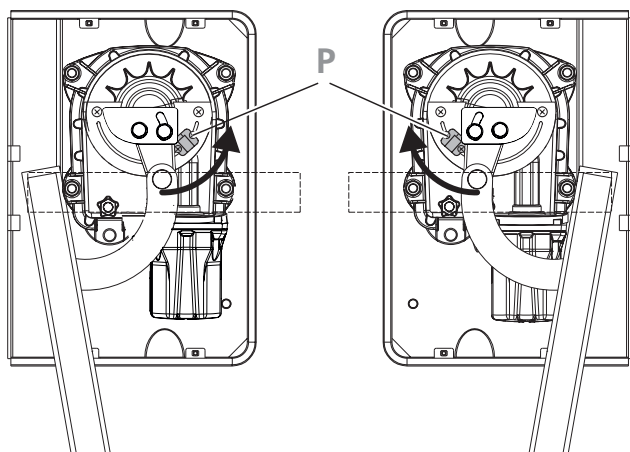

- Attach the reference point sensor (P) so that the rotatable arm moves over the reference point sensor every time that the gate moves.

4.9 Setting the limit stops

4.9.1 Setting the CLOSED gate position

4.9.1 / 1

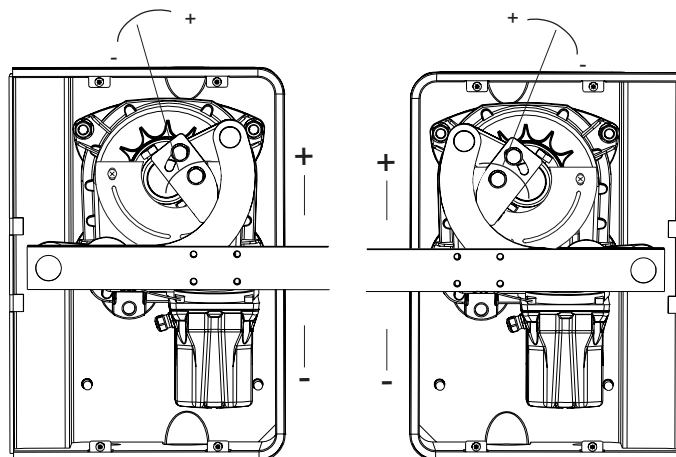

- Set the limit stop with the aid of the the fixing screws (O).

The limit stop can be adjusted between an angle of 85° - 95° in the CLOSED gate setting.

- + Gate closes further
- Gate does not close as far

4.9.2 Setting the OPEN gate position

If the gate system has a gate stop in the OPEN direction, the OPEN travel limit stop does not need to be set.

- Close the wing of the gate.

4.9.2 / 1

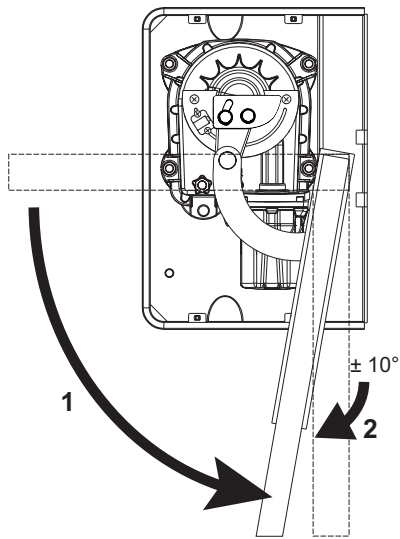

- Open the gate wing to its full extent (1).
- Close the gate wing approx. 10° (2).

4.9.2 / 2

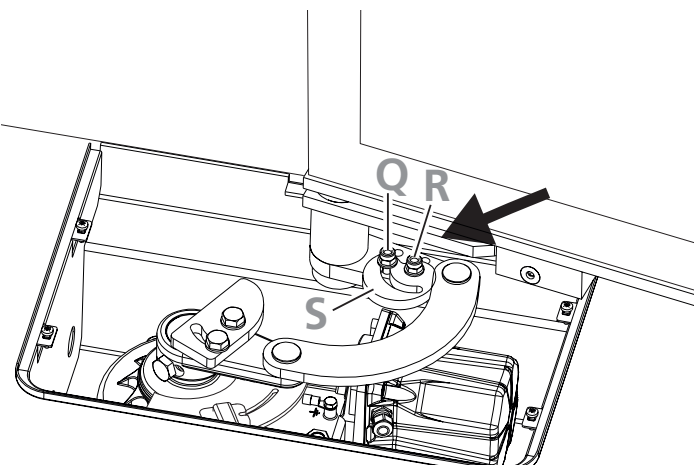

- Loosen screws (Q) and (R).
- Rotate the cam (S) as far as it will go with the aid of the connecting rod.
- Tighten screws (Q) and (R).

The gate wing opening can be adjusted by setting the cam (Q).

4.10 Completing the installation

- Close the operator housing with the cover plate.
- Screw down the cover plate.

✓ CHECK

To ensure that installation is correct, the following tests must be carried out:

- Release the operator.
- "5.2 Release mechanism"
- Move the gate slowly by hand into the OPEN and CLOSED end positions.

4.10 / 1

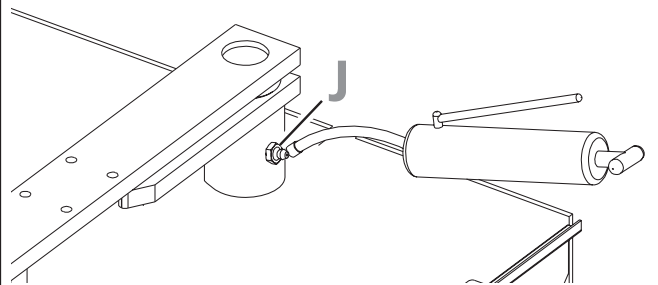

- Lubricate the wing device through the lubricating nipple (J) until grease escapes on both sides (grease DIN 51502 KP 2 N - K 2 K-20).

4.11 Connecting to the junction box

4.11 / 1

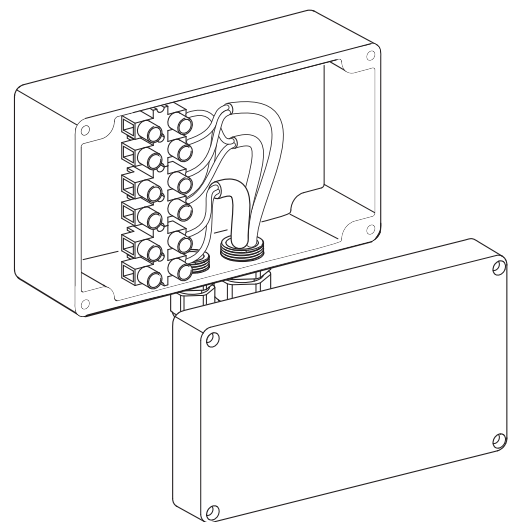

- Thread the connection cables from the motor unit through the cable gland and into the junction box housing.
- Attach the connection cables as required.
- "4.12 / 1"

4.12 Connection to the control unit

To operate the motor unit, the junction box must be connected to a suitable control unit (not included in the scope of supply).

REFERENCE

Follow the instructions in the relevant documentation when connecting the operator to the control unit.

4.12 / 1 M12E030 b

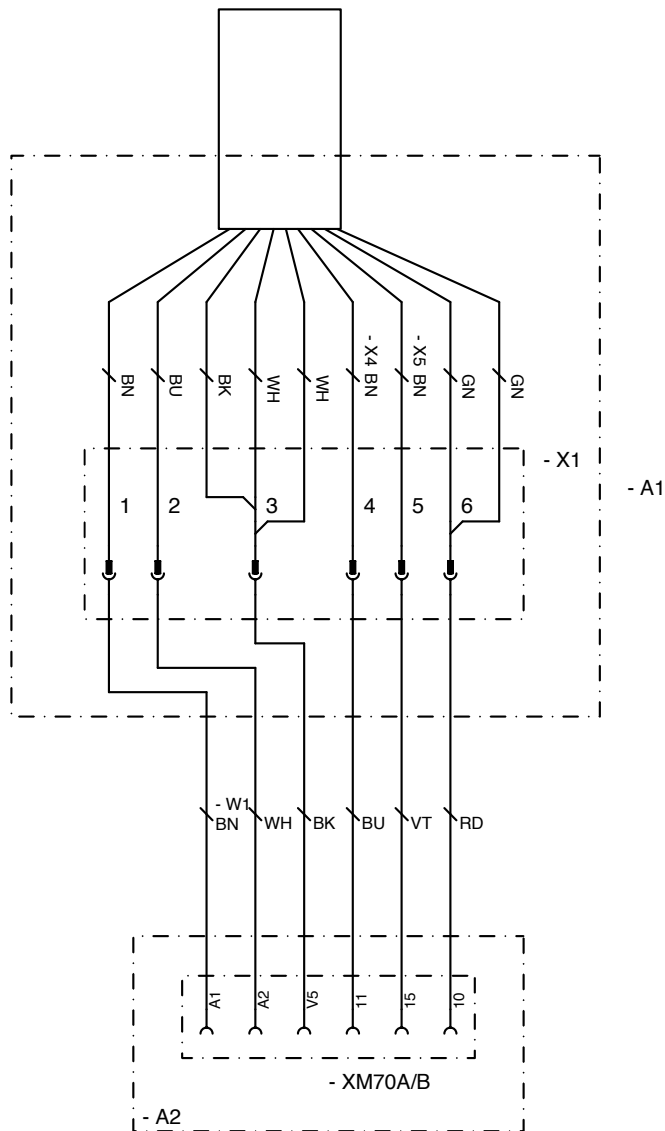

A1	Junction box housing → "4.11 Connecting to the junction box"
A2	Control unit: Control x.52
M1	Motor unit
X4	RPM sensor
X5	Reference point sensor

5. Operation

5.1 Hand transmitter

REFERENCE

Follow the instructions in the relevant documentation for operation with a hand transmitter.

5.2 Release mechanism

REFERENCE

The procedure for releasing the operator is described in the documentation provided with it.

6. Maintenance

To ensure fault-free operation, the gate system must be inspected regularly and, if necessary, be repaired. Before starting work on the gate system, the operator system must always be disconnected from the power supply.

- Check once a month that the operator system reverses when the gate touches an obstacle. Place an obstacle in the path of the gate to check this.
- Check all the moving parts of the gate system and gate operator system.
- Check the gate system for signs of damage or wear and tear.
- Move the gate manually to check that the gate travels easily and smoothly.
- Check that the photocell functions properly.
- Check that the closing edge safety device functions properly.
- Check the power supply cable for signs of damage.

For safety reasons, if the power supply cable is damaged it must be replaced by the manufacturer or his customer service department, or by a similarly qualified person.

Care and cleaning

DANGER!

Life-threatening danger due to electric shock!

- It is vital that you disconnect the operator system from the power supply before commencing cleaning work. Take measures to ensure that the power supply remains disconnected for the duration of the cleaning work.

NOTICE

Damage to property due to incorrect handling!

When cleaning the operator system, never use:

direct water jets, high pressure cleaners, acids or alkaline solutions.

- Clean the outside of the housing with a soft, damp, lint-free cloth.

If heavily soiled, the housing can be cleaned with a mild detergent.

7. Disassembly

DANGER!

Life-threatening danger due to electric shock!

- It is vital that you disconnect the operator system from the power supply before commencing dismantling work. Take measures to ensure that the power supply remains disconnected for the duration of the dismantling work.

WARNING!

Possibility of serious injury due to incorrect dismantling!

- Comply with all applicable occupational health and safety regulations.

The system must be disassembled by a qualified person, following the installation instructions in reverse order.

8. Disposal

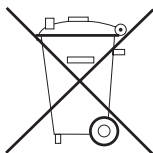

Do not dispose of old equipment or batteries with the normal household waste!

- Dispose of old devices at a waste collection centre for electronic waste or via a specialist dealer.
- Dispose of old batteries in a battery recycling container or via a specialist dealer.
- Dispose of the packaging material in the special waste collection containers for paper, cardboard and plastic.

9. Rectifying faults

REFERENCE

To rectify faults, follow the instructions in the control unit documentation.

10. Appendix

10.1 Technical data

Electrical data

Duty cycle	min.	short-term 5
Control voltage	V DC	24
Protection category of motor unit		IP 67
Protection class		II

Mechanical data

Max. torque	Nm	Comfort 585: 250 Comfort 586: 300
Travel speed	mm/s	15-20
Opening time, dependent on gate type	s	18

Environmental data

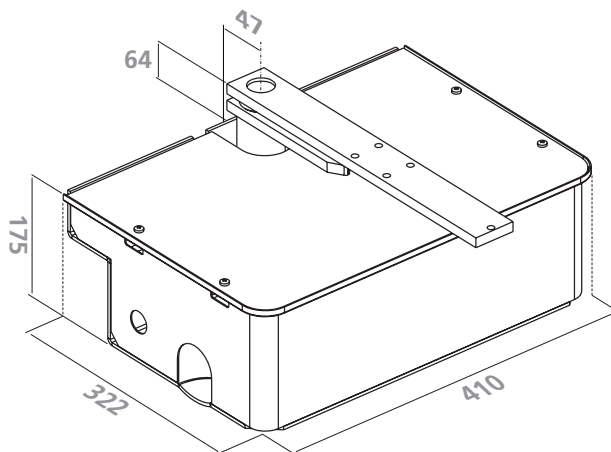

Dimensions of motor unit



Weight	kg	Comfort 585: 12.0 Comfort 586: 12.5
--------	----	--

Weight (double wing gate)	kg	Comfort 585: 24.0 Comfort 586: 25.0
---------------------------	----	--

Sound pressure level	dB(A)	< 70
----------------------	-------	------

Temperature range		°C	-20
		°C	+55

* without any additional equipment connected

Use	Comfort		
		585	586
Hinged gates			
– Max. gate wing width	mm	2,500	3,000
– Max. gate wing weight			
for gate width up to 1.0 m	kg	250	600
for gate width up to 2.0 m	kg	150	400
for gate width up to 2.5 m	kg	100	250
for gate width up to 3.0 m	kg	–	150
– Opening angle	° max.	110	110
– Gate incline	% max.	0	0

10.2 Declaration of Incorporation

We hereby declare that in its design and construction, and in the form as delivered, the product mentioned below complies with the basic requirements of the Machinery Directive 2006/42/EC.

EC Machinery Directive 2006/42/EC Annex I, with the following basic health and safety requirements:

Sections: 1.1.2, 1.1.3, 1.1.5, 1.1.6, 1.2.1, 1.2.2, 1.2.3, 1.2.6, 1.3.2, 1.3.3, 1.3.4, 1.3.7, 1.3.9, 1.5.1, 1.5.2, 1.5.4, 1.5.6, 1.5.8, 1.5.9, 1.5.10, 1.5.11, 1.5.13, 1.5.14, 1.6.1, 1.6.3, 1.7.1, 1.7.2, 1.7.3, 1.7.4

This declaration shall no longer be valid if changes are made to the product without our authorisation.

Product: Comfort 585, 586 hinged gate operator
Revision status: R01

This partly completed machine also complies with the all of the regulations of the:

EC – Construction Products Directive EU/305/2011

EC – Electromagnetic Compatibility Directive 2004/108/EC

EC – Low Voltage Directive 2006/95/EC

Specifications from applied and referenced standards:

EN ISO 13849-1, Safety of machinery – Safety-related parts of control systems – Part 1: General principles for design, Cat. 2 / PL “C” for the power limitation function and the travel limit recognition function

EN 60335-1/2, Safety of electrical appliances/Drives for doors – as applicable

EN 61000-6-2, Electromagnetic compatibility – Emitted interference

EN 61000-6-3, Electromagnetic compatibility – Immunity

The special technical documents were prepared in accordance with Annex VII, Part B of the Machinery Directive 2006/42/EC. We undertake to supply these documents, in electronic form and within a reasonable period, in response to a duly reasoned request from the market surveillance authorities.

The partly completed machine may not be set in operation until it has been ascertained that the machine in which the partly completed machine is to be installed complies with all the requirements of the Machinery Directive 2006/42/EC.



14.01.2015

M. Hörmann
Management



Person authorised to compile the relevant technical documentation:
Marantec Antriebs- und Steuerungstechnik GmbH & Co. KG
Remser Brook 11 · 33428 Marienfeld · Germany

Phone: +49 5247 705-0

Identification plate, motor unit 1

Type A	_____
Rev (B)	_____
Art. no. (C)	_____
Prod. no. (GB)	_____

Identification plate, motor unit 2 (only double wing)

Type A	_____
Rev (B)	_____
Art. no. (C)	_____
Prod. no. (GB)	_____

