

# Comfort 530 L





101069 Comfort 530 L

## Article

Item no.	Description	Price
101068	<b>Comfort 530 L</b> Set for 1-leaf swing gates up to 3.5 m: 24 V-DC motor, 3,000 N, 20 cm/s, 115°	1062.00 €
101069	<b>Comfort 530 L</b> Set for 2-leaf swing gates up to 3.5 m: 24 V-DC motor, 3,000 N, 20 cm/s, 115°	1359.00 €

## Scope of delivery

### 101068

- Motor unit, pre-wired 6x0.75 mm<sup>2</sup> 1,500 mm
- External control Control x.52
- Digital 921 Module receiver, 868 MHz bi.linked
- Digital 564 mini hand transmitter 4-channel, 868 MHz bi.linked
- Gate and angle bracket
- Installation material

### 101069

- First and second motor unit, pre-wired 6x0.75 mm<sup>2</sup> 1,500 mm
- External control unit Control x.52
- Digital 921 Module receiver, 868 MHz bi.linked
- Digital 564 mini hand transmitter 4-channel, 868 MHz bi.linked
- Gate and pillar angle
- Installation material

# Features

## Opener

- Current-dependent obstacle detection - no active closing edge protection necessary
- End position setting directly at the control
- Reference point technique
- Concealed running operator unit
- Very quiet mechanism
- All mechanical parts protected against weather influences
- Sturdy die-cast aluminum housing and UV-resistant plastic covers
- Gate and pillar angle for easy motor installation
- Lockable unlocking device
- Can be used on rising gates up to a slope of 10% (additional accessories required)

## Structure and connection

- Pluggable radio receiver
- Connection (conventional) for push button
- Connection (conventional) for 2-wire or 4-wire photoelectric sensor OPEN and CLOSED
- Connection (conventional) for holding circuit
- Connection (conventional) for 8.2 kOhm contact strip OPEN and CLOSED
- Connection (conventional) for 24 V-DC signal light
- Connection (conventional) for electric lock 24 V-DC
- Connection (MS bus) for handheld programmer and expansion modules
- Connection for battery backup
- Output 24 V-DC, max. 50 mA

## Operation

- Marantec EOS programming
- Programming and status message via LC display
- Programming and diagnostics possible via optional external handheld programmer

## Functions

- Power-saving technology
- Soft start/soft stop/soft run
- Electronic anti-deferral device
- Blocking protection
- Runtime limit
- Automatic feed function (can only be used in conjunction with a light barrier)
- Gate open time and prewarning time separately programmable
- Lighting duration programmable and switchable by radio
- Automatic cut-out OPEN and CLOSE separately programmable
- Partial opening programmable
- Active leaf function programmable for 2-leaf gates
- Running speed OPEN and CLOSE separately programmable
- Soft run position OPEN and CLOSE separately programmable
- Soft run speed OPEN and CLOSE separately programmable
- Relay output programmable: signal light, door position OPEN or CLOSED, wipe impulse (1 s), fault, lighting
- Cycle counter
- Maintenance interval programmable
- Error signaling with error memory
- Multi-level reset function (control, safety, radio, etc.)

# Technical data

	Comfort 530 L
Operating mode (duty cycle)	S2 - 5 min
Push and pull force (max.) [N]	3,000
Running speed (max.) [cm/s]	2
Opening angle (max.) [°]	115
Motor voltage [V]	24 V-DC
End position system	Reference point technique
Protection class	IP44

# Technical drawings

**Comfort 530 L**

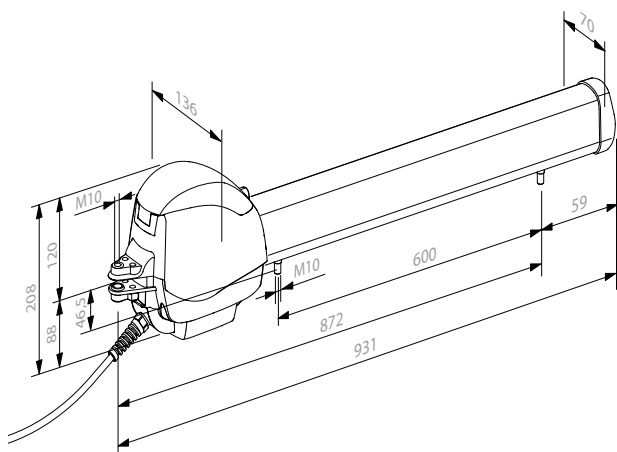

**Control x.52**

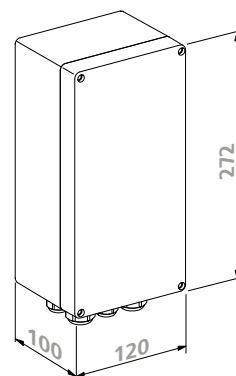

## Area of use

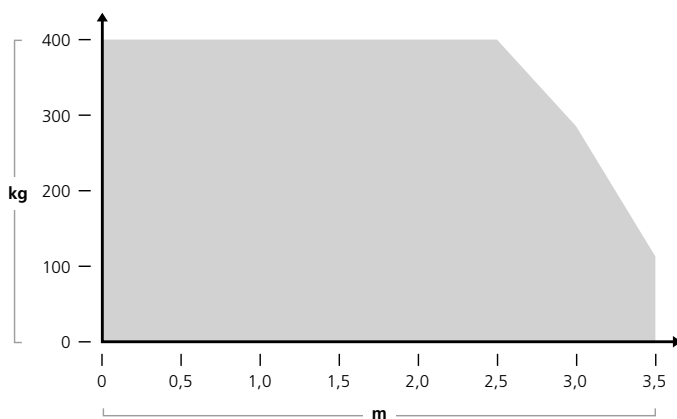

● Comfort 530 L

## Operator specific accessories



**Special 530**

Fastening set for swing gates with rising hinges and a slope of max. 10%

104733  
100.00 €



**Special 516**

Connection cable 6x0.75 mm<sup>2</sup> with cable cover for direct installation in the operator housing, 10 m

167922  
43.00 €



**Connecting cable**

8x0.75 mm<sup>2</sup>, 10 m

102670  
41.00 €

## Technical data

	Comfort ST3024	Comfort ST5024E	Comfort RA2224	Comfort RA2224E	Comfort RA4224E
Width gate wing (max.) [m]	3	5	3		4
Height gate wing (max.) [m]	2				
Weight of gate leaf (max.) [kg]	400	600	500		600
E dimension (min./max.) [mm]	0/0		0/230		0/200
Operating mode (duty cycle)		S2 - 8 min			
Push and pull force (max.) [N]	1,400		1,500		2,000
Running speed (max.) [cm/s]	2.5	2.7	2.6		1.5
Opening angle (max.) [°]	128	122	120		
Movement stroke (max.) [mm]	400	490	415		
Motor power [kW]	0.09	0.12	0.09		0.12
Motor voltage [V]	24 V-DC				
Encoder	No	Yes	No	Yes	
Protection class	IP44				
Continuous sound pressure level (max.) [dB(A)]	70				
Temperature (min./max.) [°C]	-20/55				

	Comfort 515	Comfort 515 L	Comfort 516	Comfort 516 L	Comfort 525	Comfort 525 L	Comfort 530 L
Width gate wing (max.) [m]	2.5	3.5	2.5	3.5	3	4	3.5
Height gate wing (max.) [m]	2						
Weight of gate leaf (max.) [kg]	200				400		350
Gradient (max.) [%]					10		
E dimension (min./max.) [mm]	0/160	0/260			0/160	0/260	100/200
Operating mode (duty cycle)	S2 - 5 min						
Push and pull force (max.) [N]	1,000				3,000		
Running speed (max.) [cm/s]	2						
Opening angle (max.) [°]	120	115	120	115	120	115	
Movement stroke (max.) [mm]	413.5	613.5	413.5	613.5	405	605	600
Motor voltage [V]	24 V-DC						
End position system	Electronic limit switches		Reference point technique				
Protection class	IP44						
Continuous sound pressure level (max.) [dB(A)]	70						
Temperature (min./max.) [°C]	-20/60						

## Technical data

	Comfort REP2224	Comfort UN3224	Comfort UN3224E
Width gate wing (max.) [m]	2.3	3.5	
Height gate wing (max.) [m]	2		
Weight of gate leaf (max.) [kg]	250	600	
E dimension (min./max.) [mm]	0/200	0/0	
Operating mode (duty cycle)	S2 - 8 min		
Output torque [Nm]	120	250	
Opening angle (max.) [°]	120	90	
Motor power [kW]	0.12		
Motor voltage [V]	24 V-DC		
Encoder	No		Yes
Protection class	IP44	IP67	
Continuous sound pressure level (max.) [dB(A)]	70		
Temperature (min./max.) [°C]	-20/55		

# Swing Gate Operators





Comfort ST300



Comfort ST500



Comfort RA



Comfort 515/515 L



Comfort 516/516 L



Comfort 525/525 L



Comfort 530 L



Comfort RE+

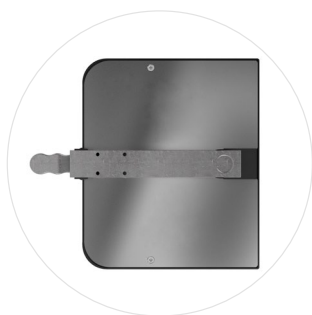

Comfort UN