

Comfort 510 S

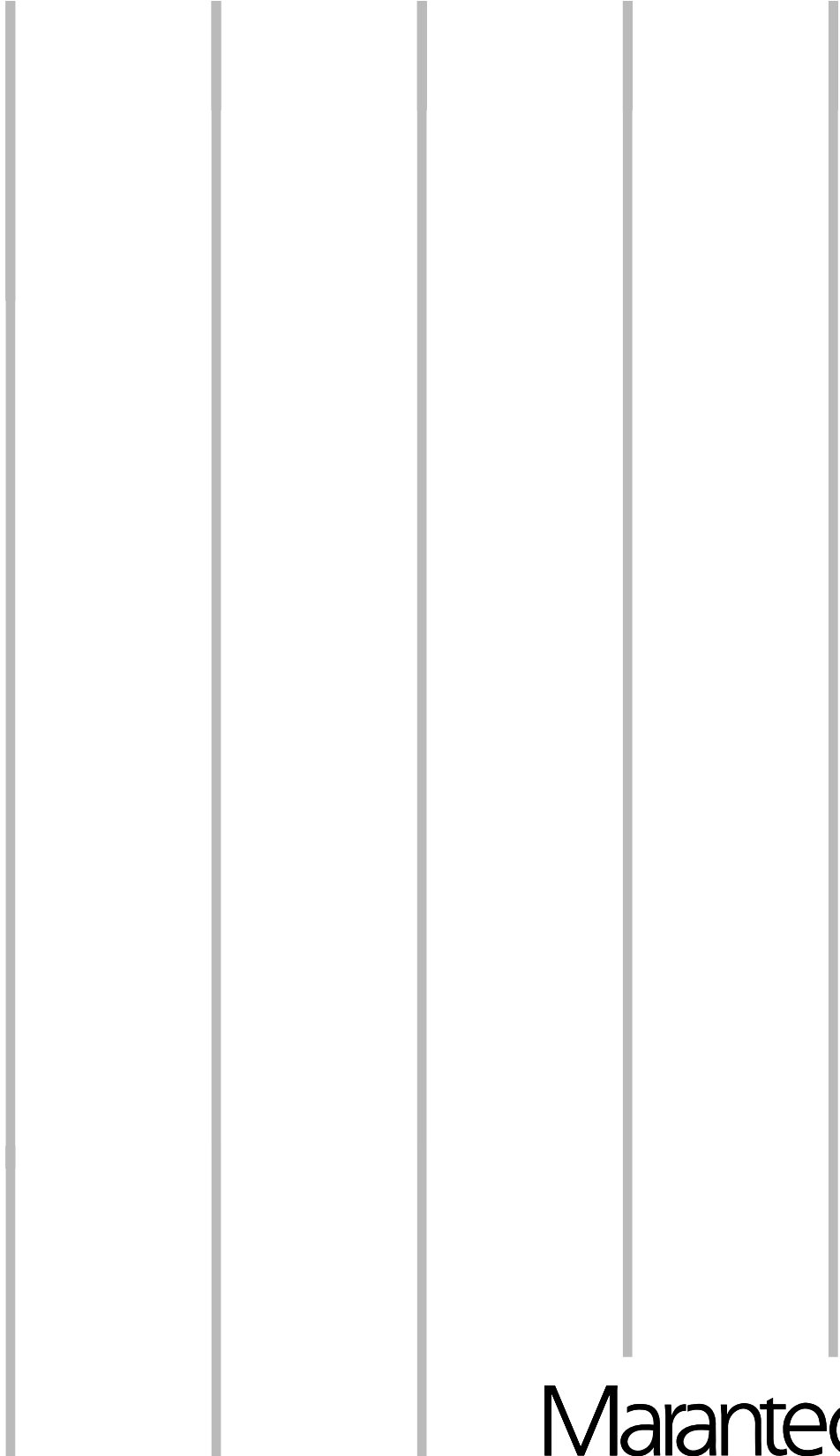

1

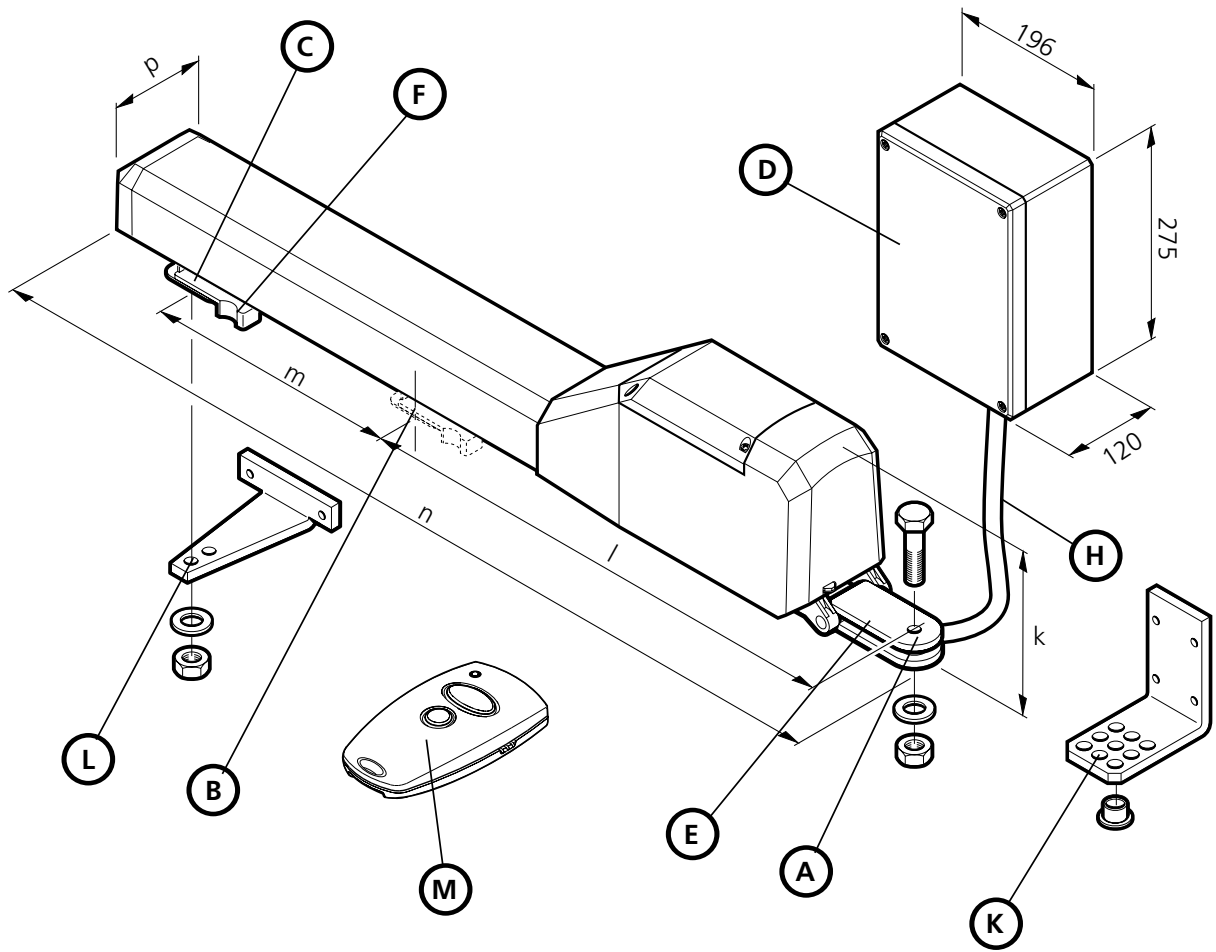

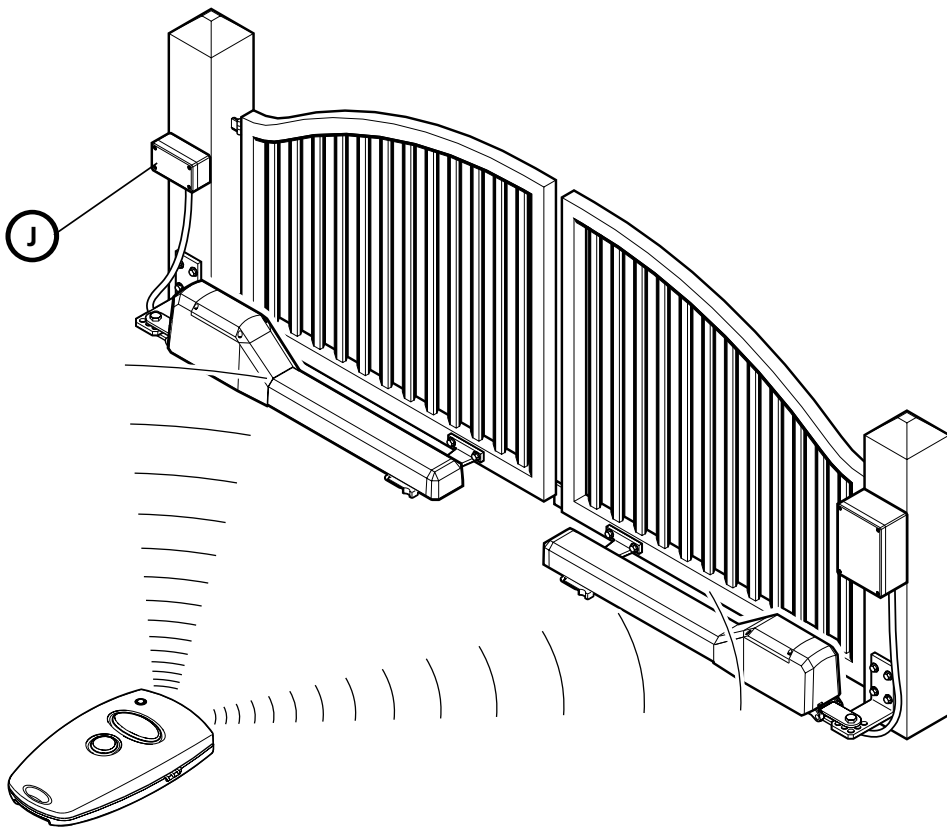
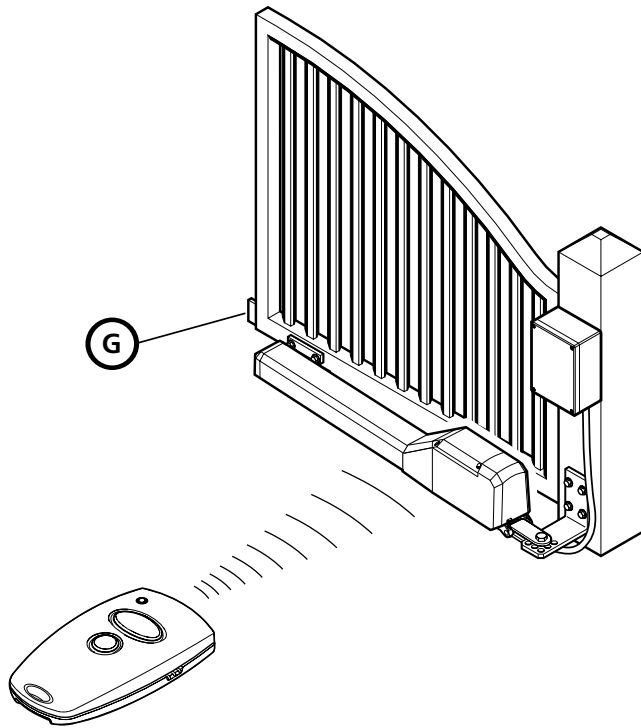

2

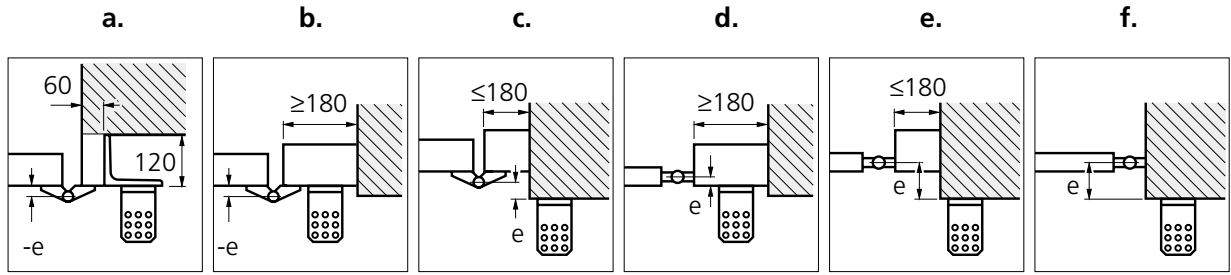

3

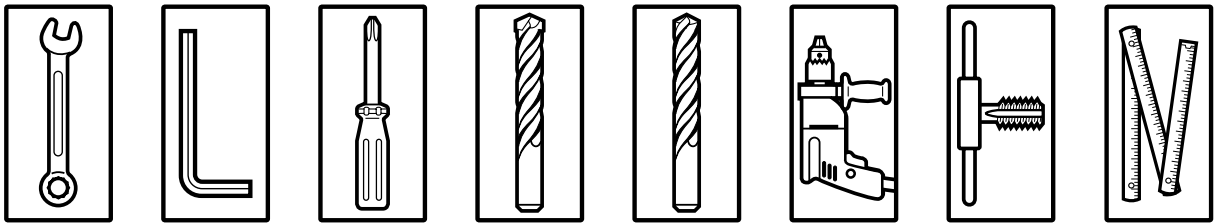

4

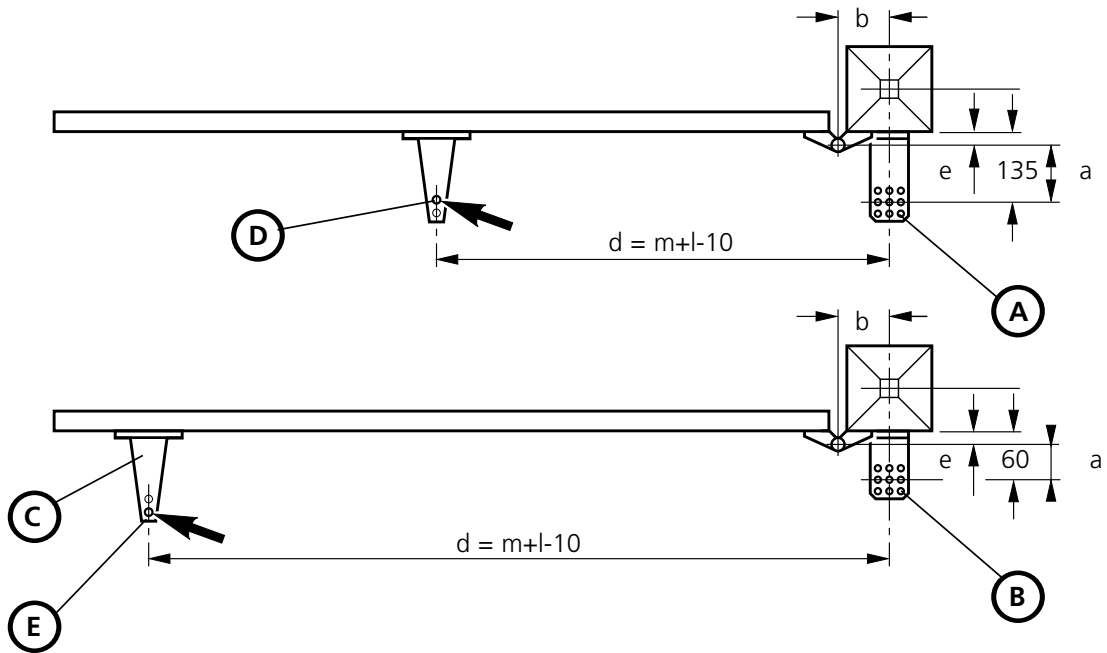

5

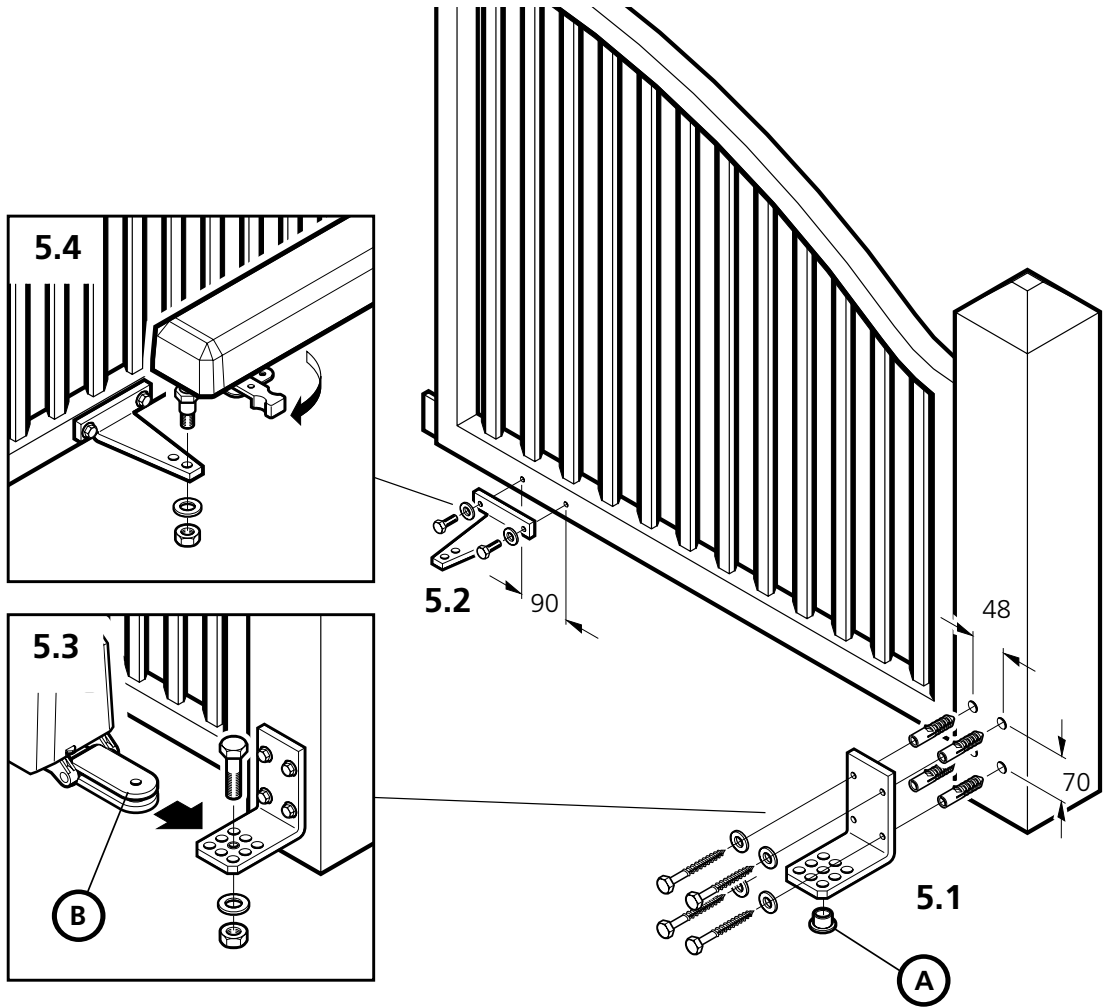

6

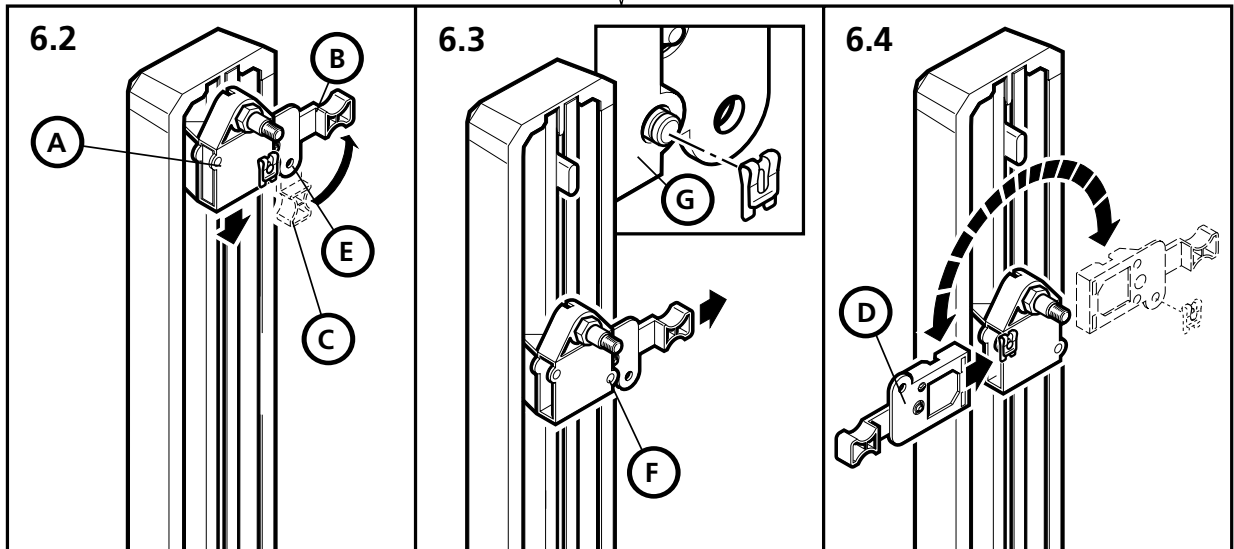
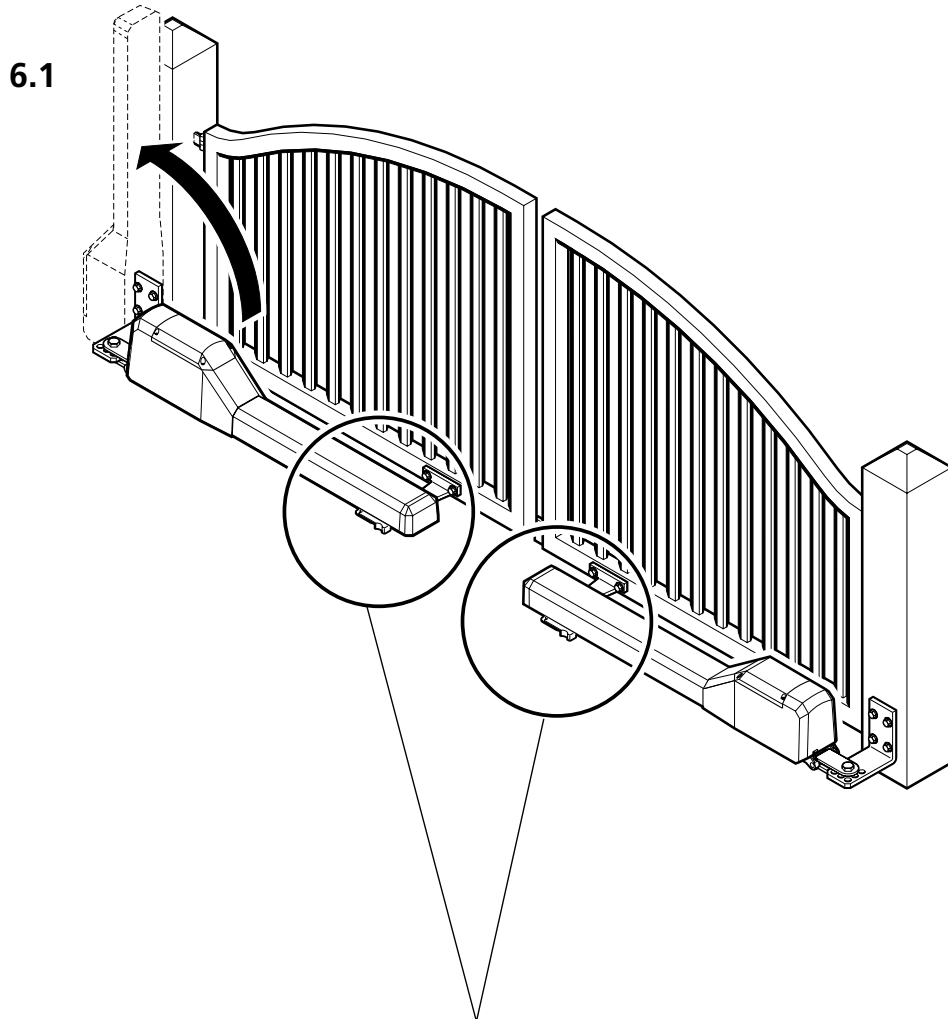

7

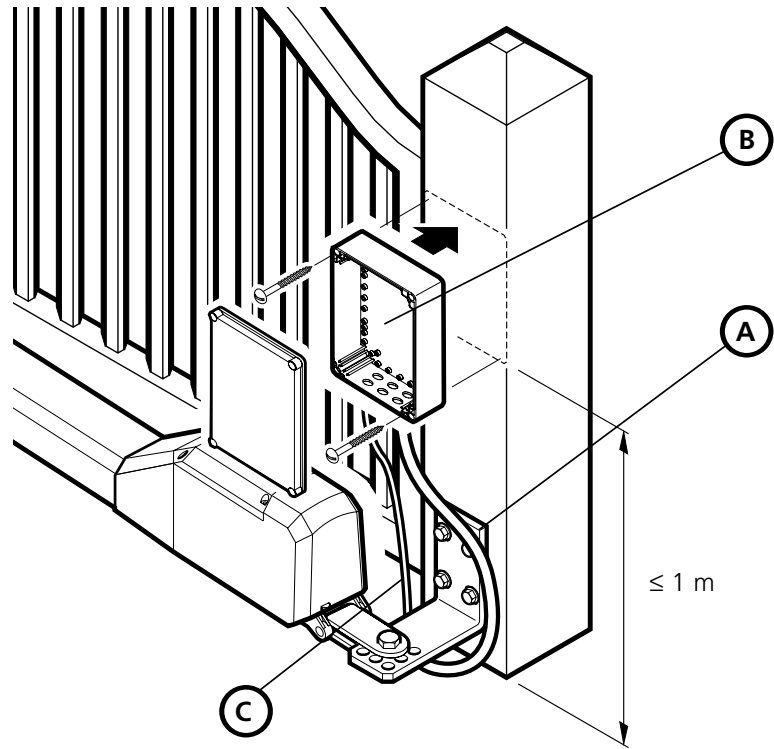

8

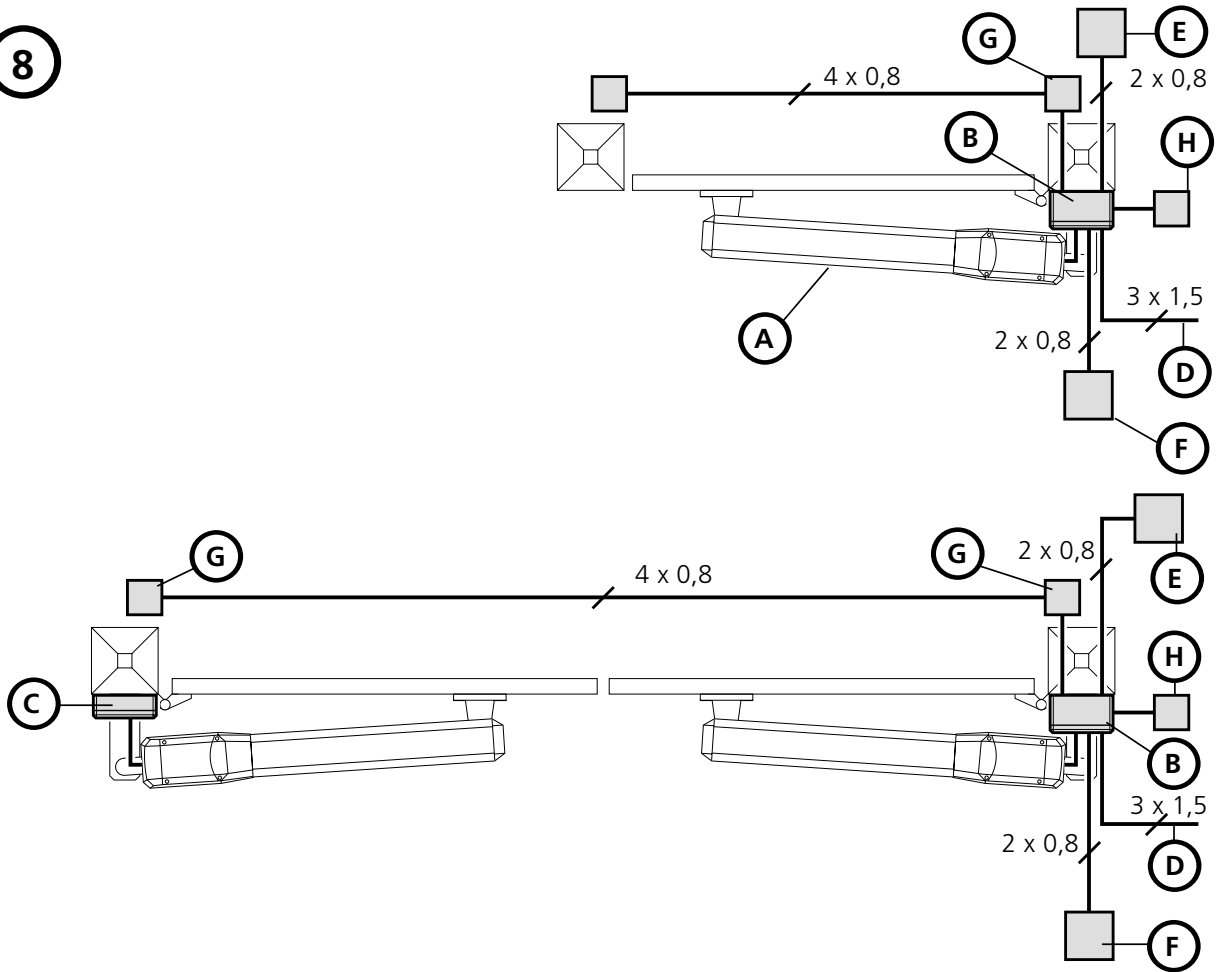

9

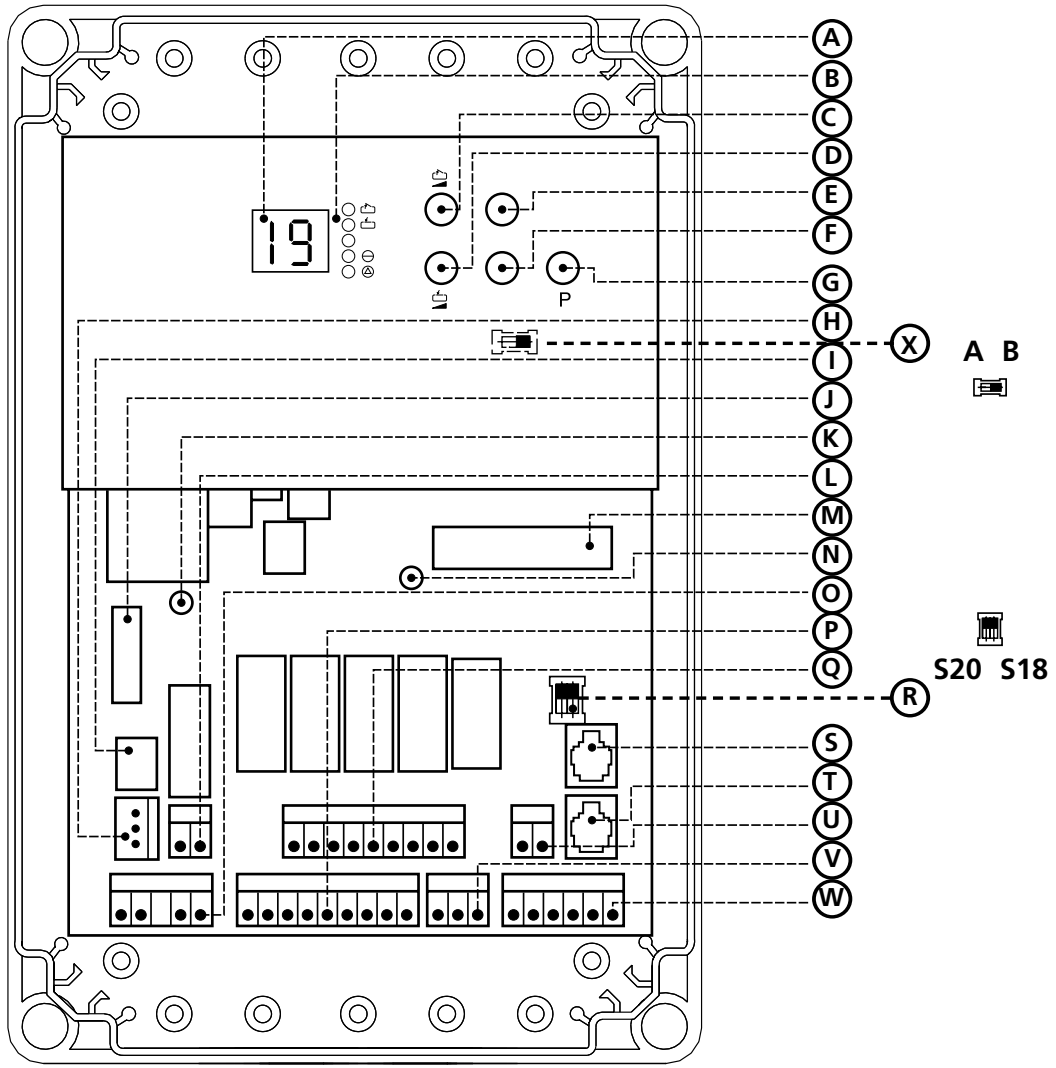

10

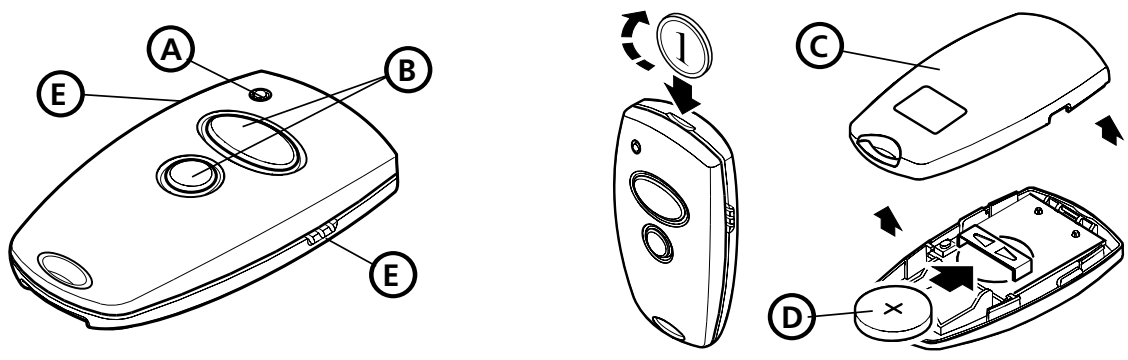

11

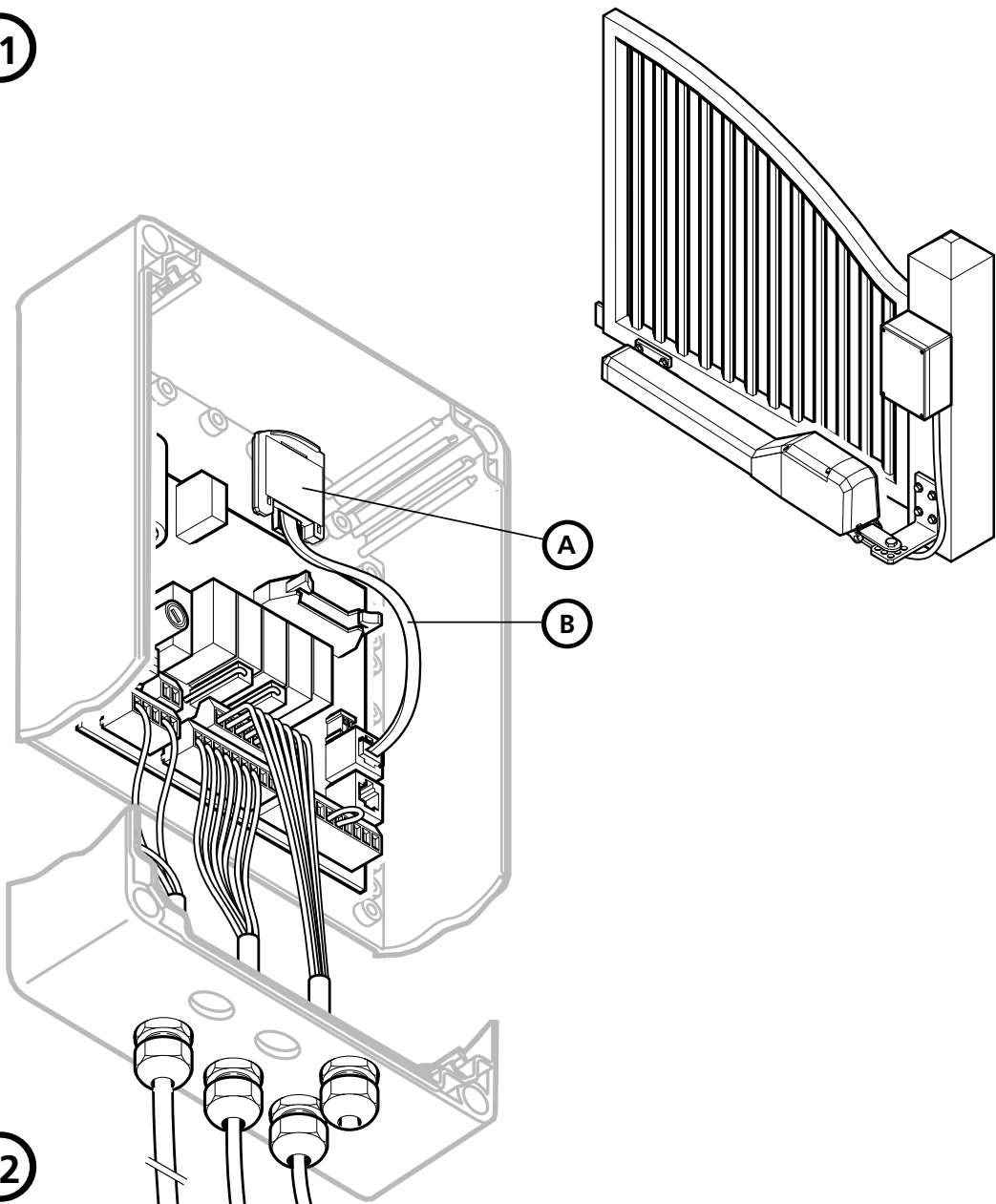

12

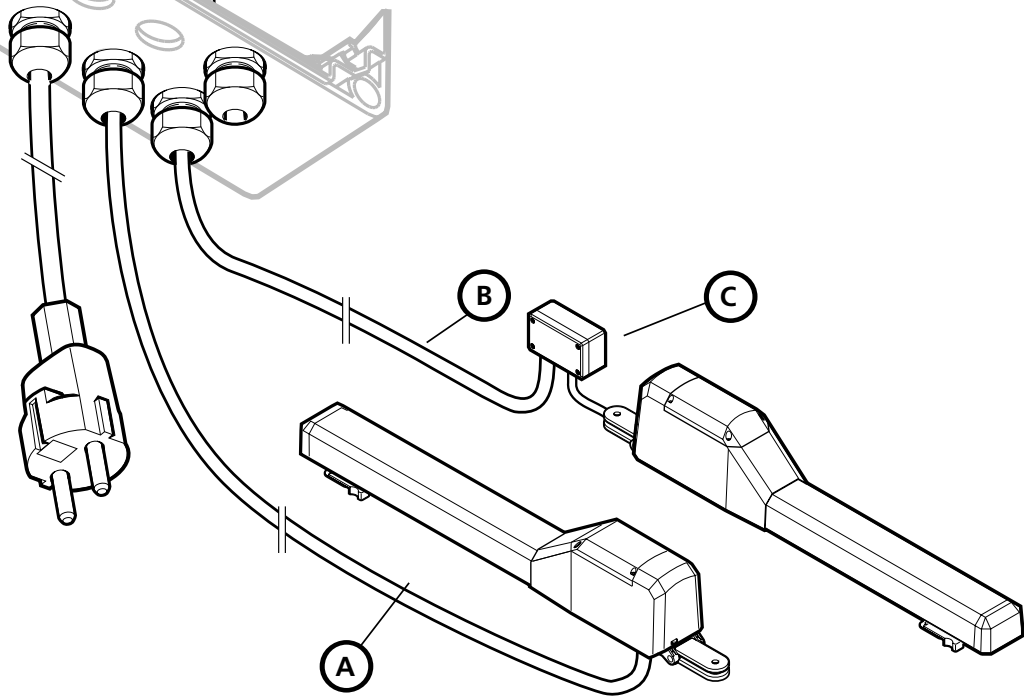

13

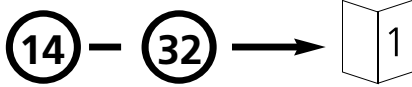
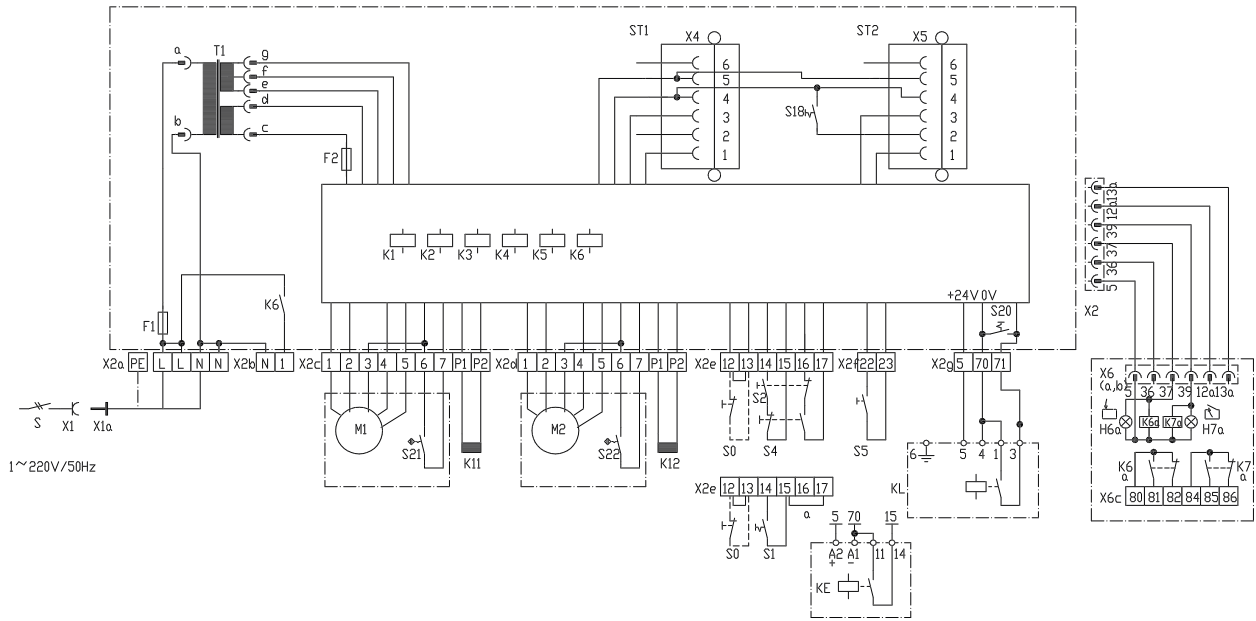

Comfort 510 S

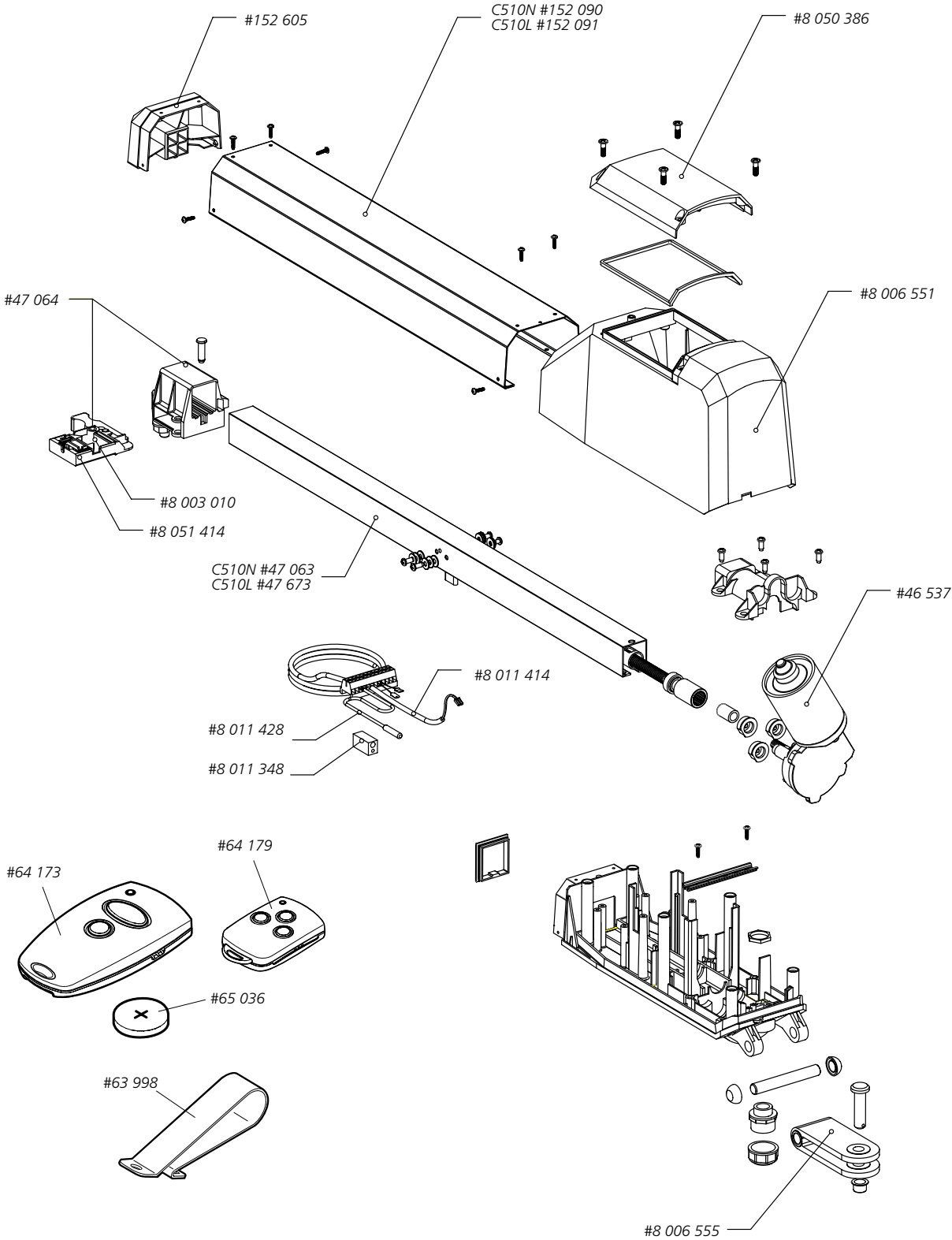

- D** Urheberrechtlich geschützt.
Nachdruck, auch auszugsweise, nur mit unserer Genehmigung.
Änderungen, die dem technischen Fortschritt dienen, vorbehalten.
- GB** Copyright.
No part of this manual may be reproduced without our prior written approval.
We reserve the right to make technical changes in the interests of progress.
- F** Copyright
Toute reproduction même partielle interdite sans notre accord préalable.
Tous changements de construction réservés.
- NL** Door de auteurswet beschermd.
Niets uit deze uitgave mag worden verveelvoudigd en/of openbaar gemaakt door middel van druk, fotocopie, microfilm of op welke andere wijze dan ook zonder voorafgaande toestemming van de uitgever.
Technische wijzigingen voorbehouden.
- I** Diritti d'autore riservati.
Riproduzione, anche solo parziale, previa nostra autorizzazione.
La Ditta si riserva la facoltà di apportare modifiche al prodotto che servono allo sviluppo tecnologico.
- E** Copyright.
Prohibida la reproducción íntegra o parcial sin nuestra autorización.
Reservado el derecho a modificaciones en el interés del perfeccionamiento técnico.
- P** Reservados os direitos de autor.
Reprodução, mesmo parcialmente, só com a nossa autorização.
Sujeito a alterações que sirvam a evolução técnica.
- S** Upphovsrättsskyddad.
Eftertryck, även delvis, endast med vårt tillstånd.
Med förbehåll för ändringar som tjänar den tekniska utvecklingen.
- N** Beskyttet opphavsrett.
Ettertrykk - også i utdrag - bare med vår tillatelse.
Endringer, som tjener den tekniske utviklingen, forbeholdes.
- H** Szerzői jogvédelem alatt.
Utánnyomás, kivonatosan is, csak engedélyünkkal.
A műszaki fejlődést szolgáló módosítások jogát fenntartjuk magunknak.
- SLO** Vse avtorske pravice so zaščitene.
Ponatis, tudi v izvlečkih, je možen samo z dovoljenjem
Spremembe ki so namenjene tehničnemu izboljšanju so tudi pridržane.
- CZ** Chráněno autorským právem.
Přetisk tohoto návodu včetně jeho částí je přípustný pouze s naším souhlasem.
Právo změny vyvolané technickým pokrokem vyhrazeno.
- PL** Prawa autorskie zastrzeżone.
Kopiowanie, również fragmentów, tylko za zezwoleniem.
Zastrzeżenie się wprowadzanie zmian służących usprawnieniu technicznemu.