

Comfort 220.2

Operator system for garage doors



[EOS] EASY OPERATING SYSTEM

NEW

Comfort 220.2

Article	Article no.	Price each
Motor unit Comfort 220.2	83 675	

Package

- Motor unit Comfort 220 with multibit remote control 868 MHz
- Digital 302 Mini hand transmitter, 2-channel
- Universal mounting kit for up-and-over doors and sectional doors

Electrical details

Nominal voltage	230 V
Nominal frequency	50 Hz
Power consumption	1,1 A
Power input in operation	0,25 KW
Power input stand-by	approx. 4 W
Operation mode (duty cycle)	KB 2 min.
Control voltage	24 V DC
Protection category motor unit	IP 20
Protection class	II

Mechanical details

Push and pull force	600 N
Door travel speed	140 mm/sec.
Opening time (door-specific) approx.	15 sec.

General details

Measurements	(Motor unit) 220 x 125 x 395 mm
Weight	3,8 kg
Range of temperature	-20°C to +60°C
Illuminant (energy-saving lamp)	1 x 11 W, E14

Function

- Economy mode
- Reference point technique
- Electronic travel cut-out
- Soft start/soft stop
- Push-open security
- Anti-blocking device
- Excess travel stop
- Release from inside
- Connection for pushbuttons, code keypads and key switches
- Automatic cut-out 'Open' and 'Close' separately programmable
- Partial opening programmable
- Door travel speed 'Open' and 'Close' separately programmable
- Soft run position 'Open' and 'Close' separately programmable
- Soft run travel speed 'Open' and 'Close' separately programmable
- 3 minutes light programmable for lighting the garage
- Automatic timer function
- Connection potential-free limit switch information
- Retrofitting of potential-free signal relay possible, for
 - Signal light
 - Wiping impulse
 - 3 minutes light
 - Final position message
 - Alarm system
 - Malfunction message
- Error message
- Reset function

Application

- Operator system for garage doors - private use
- For up-and-over doors up to a door width of 3.500 mm and a door weight of 100 kg
- For single-walled sectional doors up to a door width of 5.000 mm and a door weight of 100 kg
- For double-walled sectional doors up to a door width of 3.000 mm and a door weight of 100 kg
- For retractable up-and-over doors and canopy doors up to a door width of 3.500 mm, a door height of 2.250 mm and a door weight of 100 kg
- For maximum 50 parking lots (corresponding to class 2 of the RAL quality mark)
- For operator rails with roller chains or toothed drive belts

Comfort 250.2

Operator system for garage doors



[EOS] EASY OPERATING SYSTEM

NEW

Comfort 250.2

Article	Article no.	Price each
Motor unit Comfort 250.2	83 676	

Package

- Motor unit Comfort 250.2 with multibit remote control 868 MHz
- Digital 302 Mini hand transmitter, 2-channel
- Digital 313 Micro hand transmitter, 3-channel
- Universal mounting kit for up-and-over doors and sectional doors

Electrical details

Nominal voltage	230 V
Nominal frequency	50 Hz
Power consumption	1,1 A
Power input in operation	0,25 KW
Power input stand-by	approx. 3 W
Operation mode (duty cycle)	KB 5 min.
Control voltage	24 V DC
Protection category motor unit	IP 20
Protection class	II

Mechanical details

Push and pull force	800 N
Door travel speed	140 mm/sec.
Opening time (door-specific) approx.	15 sec.

General details

Measurements	(Motor unit) 220 x 125 x 395 mm
Weight	4,1 kg
Range of temperature	-20°C to +60°C
Illuminant (energy-saving lamp)	1 x 11 W, E14

Function

- Economy mode
- Reference point technique
- Electronic travel cut-out
- Soft start/soft stop
- Push-open security
- Anti-blocking device
- Excess travel stop
- Release from inside
- Connection for pushbuttons, code keypads and key switches
- Automatic cut-out 'Open' and 'Close' separately programmable
- Partial opening programmable
- Door travel speed 'Open' and 'Close' separately programmable
- Soft run position 'Open' and 'Close' separately programmable
- Soft run travel speed 'Open' and 'Close' separately programmable
- 3 minutes light programmable for lighting the garage
- Automatic timer function
- Connection potential-free limit switch information
- Retrofitting of potential-free signal relay possible, for
 - Signal light
 - Wiping impulse
 - 3 minutes light
 - Final position message
 - Alarm system
 - Malfunction message
- Error message
- Reset function

Application

- Operator system for garage doors - private use
- For up-and-over doors up to a door width of 5.000 mm and a door weight of 175 kg
- For single-walled sectional doors up to a door width of 5.500 mm and a door weight of 175 kg
- For double-walled sectional doors up to a door width of 5.500 mm and a door weight of 175 kg
- For retractable up-and-over doors and canopy doors up to a door width of 5.000 mm, a door height of 2.250 mm and a door weight of 175 kg
- For maximum 50 parking lots (corresponding to class 2 of the RAL quality mark)
- For operator rails with roller chains or toothed drive belts

Comfort 252.2

Operator system for garage doors



[EOS] EASY OPERATING SYSTEM

NEW

Comfort 252.2

Article	Article no.	Price each
Motor unit Comfort 252.2	83 677	

Package

- Motor unit Comfort 252.2 with multibit remote control 868 MHz
- Digital 302 Mini hand transmitter, 2-channel
- Digital 313 Micro hand transmitter, 3-channel
- Universal mounting kit for up-and-over doors and sectional doors

Electrical details

Nominal voltage	230 V
Nominal frequency	50 Hz
Power consumption	1,1 A
Power input in operation	0,25 KW
Power input stand-by	approx. 3 W
Operation mode (duty cycle)	KB 2 min.
Control voltage	24 V DC
Protection category motor unit	IP 20
Protection class	II

Mechanical details

Push and pull force	1.000 N
Door travel speed	140 mm/sec.
Opening time (door-specific) approx.	18 sec.

General details

Measurements	(Motor unit) 220 x 125 x 395 mm
Weight	4,2 kg
Range of temperature	-20°C to +60°C
Illuminant (energy-saving lamp)	1 x 11 W, E14

Function

- Economy mode
- Reference point technique
- Electronic travel cut-out
- Soft start/soft stop
- Push-open security
- Anti-blocking device
- Excess travel stop
- Release from inside
- Connection for pushbuttons, code keypads and key switches
- Automatic cut-out 'Open' and 'Close' separately programmable
- Partial opening programmable
- Door travel speed 'Open' and 'Close' separately programmable
- Soft run position 'Open' and 'Close' separately programmable
- Soft run travel speed 'Open' and 'Close' separately programmable
- 3 minutes light programmable for lighting the garage
- Automatic timer function
- Connection potential-free limit switch information
- Retrofitting of potential-free signal relay possible, for
 - Signal light
 - Wiping impulse
 - 3 minutes light
 - Final position message
 - Alarm system
 - Malfunction message
- Error message
- Reset function

Application

- Operator system for garage doors - private use
- For up-and-over doors up to a door width of 6.000 mm and a door weight of 200 kg
- For single-walled sectional doors up to a door width of 6.000 mm and a door weight of 200 kg
- For double-walled sectional doors up to a door width of 6.000 mm and a door weight of 200 kg
- For retractable up-and-over doors and canopy doors up to a door width of 6.000 mm, a door height of 2.250 mm and a door weight of 200 kg
- For maximum 50 parking lots (corresponding to class 3 of the RAL quality mark)
- For operator rails with roller chains or toothed drive belts

Operator rails

Comfort 211, 220.2, 250.2, 250.2 speed, 252.2, 257



Roller chain, 1-part version

Article	Article no.	Price each
SK 11-L, 1-part	83 772	
Measurements (L)	3.080 mm	
Length of travel	2.475 mm	
Packing length	3.140 mm	
Weight	5,9 kg	

Article	Article no.	Price each
SK 12-L, 1-part	83 773	
Measurements (L)	3.330 mm	
Length of travel	2.725 mm	
Packing length	3.380 mm	
Weight	6,3 kg	

Article	Article no.	Price each
SK 13, 1-part	83 774	
Measurements (L)	4.090 mm	
Length of travel	3.485 mm	
Packing length	4.140 mm	
Weight	8,2 kg	

Package
· Micro-profiled operator rail, 1-part

Function/application
· To transmit the power from the operator system to the door
· Micro-profiled operator rail for the operator systems Comfort 211 (only SK 11-L and SK 12-L), 220.2, 250.2, 250.2 speed, 252.2 and 257
· The rail length depends on the door height and on the door brand

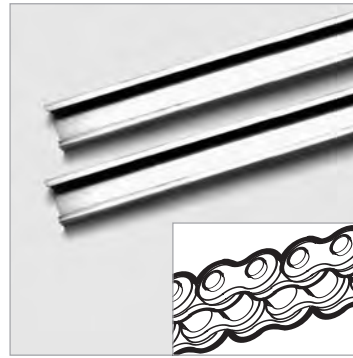

Roller chain, 2-part version

Article	Article no.	Price each
SK 11-L, 2-part	83 789	
Measurements (L)	3.080 mm	
Length of travel	2.475 mm	
Packing length	1.600 mm	
Weight	6,8 kg	

Article	Article no.	Price each
SK 12-L, 2-part	83 790	
Measurements (L)	3.330 mm	
Length of travel	2.725 mm	
Packing length	1.725 mm	
Weight	7,2 kg	

Article	Article no.	Price each
SK 13, 2-part	83 791	
Measurements (L)	4.090 mm	
Length of travel	3.485 mm	
Packing length	2.100 mm	
Weight	8,8 kg	

Package
· Micro-profiled operator rail, 2-part
· Rail connector
· Mounting material

Function/application
· To transmit the power from the operator system to the door
· Micro-profiled operator rail for the operator systems Comfort 211 (only SK 11-L and SK 12-L), 220.2, 250.2, 250.2 speed, 252.2 and 257
· The rail length depends on the door height and on the door brand

Operator rails

Comfort 211, 220.2

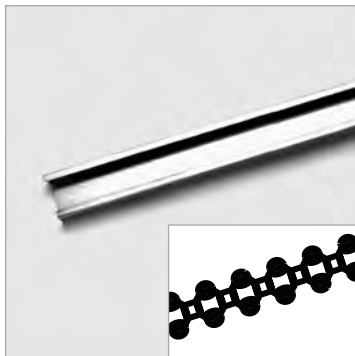

Ball rope, 1-part version

Article	Article no.	Price each
ST 11-L, 1-part	84 420	
Measurements (L)	3.080 mm	
Length of travel	2.475 mm	
Packing length	3.140 mm	
Weight 4,4	kg	

Article	Article no.	Price each
ST 12-L, 1-part	84 422	
Measurements (L)	3.330 mm	
Length of travel	2.725 mm	
Packing length	3.380 mm	
Weight	4,7 kg	

Package
· Micro-profiled operator rail, 1-part

Function/application
<ul style="list-style-type: none"> · To transmit the power from the operator system to the door · Micro-profiled operator rail for the operator systems Comfort 211 and 220.2 · The rail length depends on the door height and on the door brand

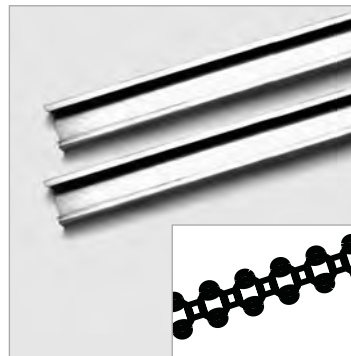

Ball rope, 2-part version

Article	Article no.	Price each
ST 11, 2-part	84 421	
Measurements (L)	3.080 mm	
Length of travel	2.475 mm	
Packing length	1.600 mm	
Weight	5,1 kg	

Article	Article no.	Price each
ST 12-L, 2-part	84 423	
Measurements (L)	3.330 mm	
Length of travel	2.725 mm	
Packing length	1.725 mm	
Weight	5,4 kg	

Package
· Micro-profiled operator rail, 2-part
· Rail connector
· Mounting material

Function/application
<ul style="list-style-type: none"> · To transmit the power from the operator system to the door · Micro-profiled operator rail for the operator systems Comfort 211 and 220.2 · The rail length depends on the door height and on the door brand

Operator rails

Comfort 211, 220.2, 250.2, 250.2 speed, 252.2, 257

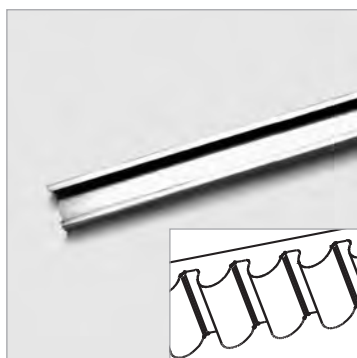

Toothed drive belt, 1-part version

Article	Article no.	Price each
SZ 11-L, 1-part	83 725	
Measurements (L)	3.080 mm	
Length of travel	2.475 mm	
Packing length	3.140 mm	
Weight	4,7 kg	

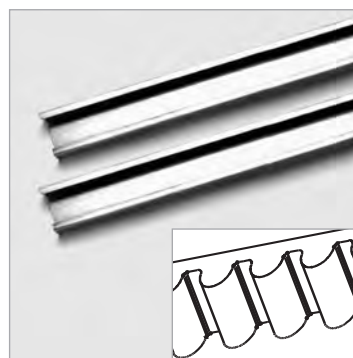

Toothed drive belt, 2-part version

Article	Article no.	Price each
SZ 11-L, 2-part	83 737	
Measurements (L)	3.080 mm	
Length of travel	2.475 mm	
Packing length	1.600 mm	
Weight	5,4 kg	

Article	Article no.	Price each
SZ 12-L, 1-part	83 726	
Measurements (L)	3.330 mm	
Length of travel	2.725 mm	
Packing length	3.380 mm	
Weight	5,0 kg	

Article	Article no.	Price each
SZ 12-L, 2-part	83 738	
Measurements (L)	3.330 mm	
Length of travel	2.725 mm	
Packing length	1.725 mm	
Weight	5,9 kg	

Article	Article no.	Price each
SZ 13, 1-part	83727	
Measurements (L)	4.090 mm	
Length of travel	3.485 mm	
Packing length	4.140 mm	
Weight	6,2 kg	

Article	Article no.	Price each
SZ 13, 2-part	83 739	
Measurements (L)	4.090 mm	
Length of travel	3.485 mm	
Packing length	2.100 mm	
Weight	7,0 kg	

Package
· Micro-profiled operator rail, 1-part

Package
· Micro-profiled operator rail, 2-part
· Rail connector
· Mounting material

Function/application
· To transmit the power from the operator system to the door
· Micro-profiled operator rail for the operator systems Comfort 211 (only SZ 11-L and SZ 12-L), 220.2, 250.2, 250.2 speed, 252.2 and 257
· The rail length depends on the door height and on the door brand

Function/application
· To transmit the power from the operator system to the door
· Micro-profiled operator rail for the operator systems Comfort 211 (only SZ 11-L and SZ 12-L), 220.2, 250.2, 250.2 speed, 252.2 and 257
· The rail length depends on the door height and on the door brand