

Comfort 257

1.8 Operator system for garage doors



Comfort 257 with Control 53

Article	Article no.	Price each
Motor unit Comfort 257	65 840	

Package

- Motor unit Comfort 257, pre-cabled
- Separate control unit Control x.21, pre-cabled
- Universal mounting kit for up-and-over doors and sectional doors

Electrical details

Nominal voltage	230 V
Nominal frequency	50/60 Hz
Power consumption	1 A
Power input in operation	0,2 KW
Power input stand-by	4,6 W
Operation mode (duty cycle)	KB 5 min.
Control voltage	24 V DC
Protection category	(Motor unit) IP 20 (Control unit) IP 65
Protection class	I

Mechanical details

Push and pull force	1.000 N
Door travel speed	140 mm/sec.
Opening time (door-specific) approx.	18 sec.

General details

Measurements	(Motor unit) 214 x 156 x 393 mm (Control unit) 195 x 275 x 125 mm
Weight (total)	10,1 kg
Range of temperature	-20°C to +60°C

Function

- Reference point technique
- Soft start/soft stop
- Push-open security device
- Automatic cut-out
- Anti-blocking device
- Excess travel stop
- Automatic timer function
- Electronic travel cut-out
- Economy mode
- Release from inside
- Signal light connection (can be programmed)
- Connection for pushbuttons, code keypads and key switches
- Connection possibility for garage door lighting
- Connection potential-free limit switch information
- Error message
- Reset function
- Door travel speed can be programmed
- Partial opening can be programmed
- Soft run in 'Close' direction can be programmed

Application

- Operator system for garage doors – industrial use
- For up-and over doors up to a door width of 6.000 mm and a door weight of 200 kg
- For single-walled sectional doors up to a door width of 6.000 mm and a door weight of 200 kg
- For double-walled sectional doors up to a door width of 6.000 mm and a door weight of 200 kg
- For retractable up-and-over doors and canopy doors up to a door width of 6.000 mm, a door height of 2.250 mm and a door weight of 200 kg
- For maximum 50 parking lots, 100 operations (equates to RAL-certification mark class III /80.000 cycles)
- For operator rails with roller chain or toothed drive belt

Comfort 257

Operator system for garage doors

1.9



Comfort 257 with Control x.21

Article	Article no.	Price each
Motor unit Comfort 257	82 456	

Package

- Motor unit Comfort 257, pre-cabled
- Separate control unit Control 53, pre-cabled
- Universal mounting kit for up-and-over doors and sectional doors

Electrical details

Nominal voltage	230 V
Nominal frequency	50/60 Hz
Power consumption	1 A
Power input in operation	0,2 KW
Power input stand-by	3,6 W
Operation mode (duty cycle)	KB 5 min.
Control voltage	24 V DC
Protection category	(Motor unit) IP 20 (Control unit) IP 65
Protection class	I

Mechanical details

Push and pull force	1.000 N
Door travel speed	140 mm/sec.
Opening time (door-specific) approx.	18 sec.

General details

Measurements	(Motor unit) 214 x 156 x 393 mm (Control unit) 195 x 275 x 125 mm
Weight (total)	10,1 kg
Range of temperature	-20°C to +60°C

Function

- Reference point technique
- Soft start/soft stop
- Push-open security device
- Anti-blocking device
- Excess travel stop
- Release from inside
- Connection for pushbuttons, code keypads and key switches
- Connection photocell 'Open' and 'Close'
- Connection closing edge safety device 8,2 kΩ 'Open' and 'Close'
- Connection traffic control Control x.301
- Automatic cut-out 'Open' and 'Close' separately programmable
- Partial opening can be programmed
- Door travel speed 'Open' and 'Close' separately programmable
- Soft run position 'Open' and 'Close' separately programmable
- Soft run travel speed 'Open' and 'Close' separately programmable
- Automatic timer function
- Signal relay for signal light 230 V
- Signal relay for:
 - Wiping impulse
 - 3 minutes light
 - Final position message
 - Alarm system
 - Malfunction message
- Error message
- Reset function

Application

- Operator system for garage doors – industrial use
- For up-and over doors up to a door width of 6.000 mm and a door weight of 200 kg
- For single-walled sectional doors up to a door width of 6.000 mm and a door weight of 200 kg
- For double-walled sectional doors up to a door width of 6.000 mm and a door weight of 200 kg
- For retractable up-and-over doors and canopy doors up to a door width of 6.000 mm, a door height of 2.250 mm and a door weight of 200 kg
- For maximum 50 parking lots, 100 operations (equates to RAL-certification mark class III /80.000 cycles)
- For operator rails with roller chain or toothed drive belt

Operator rails

1.10 Comfort 211, 220.2, 250.2, 250.2 speed, 252.2, 257

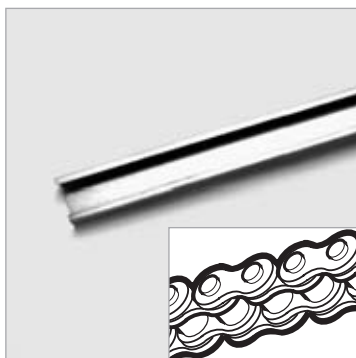

NEW

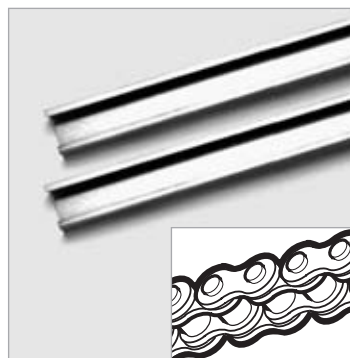

NEW

Roller chain, 1-part version (0,8 mm)

Article	Article no.	Price each
SK 11, 1-part	83 772	
Measurements (L)	3.080 mm	
Length of travel	2.475 mm	
Packing length	3.140 mm	
Weight (total)	5,9 kg	

Roller chain, 2-part version (0,8 mm)

Article	Article no.	Price each
SK 11, 2-part	83 789	
Measurements (L)	3.080 mm	
Length of travel	2.475 mm	
Packing length	1.600 mm	
Weight (total)	6,8 kg	

Article	Article no.	Price each
SK 12, 1-part	83 773	
Measurements (L)	3.330 mm	
Length of travel	2.725 mm	
Packing length	3.380 mm	
Weight (total)	6,3 kg	

Article	Article no.	Price each
SK 12, 2-part	83 790	
Measurements (L)	3.330 mm	
Length of travel	2.725 mm	
Packing length	1.725 mm	
Weight (total)	7,2 kg	

Article	Article no.	Price each
SK 13, 1-part	83 774	
Measurements (L)	4.090 mm	
Length of travel	3.485 mm	
Packing length	4.140 mm	
Weight (total)	8,2 kg	

Article	Article no.	Price each
SK 13, 2-part	83 791	
Measurements (L)	4.090 mm	
Length of travel	3.485 mm	
Packing length	2.100 mm	
Weight (total)	8,8 kg	

Package
· Micro-profiled operator rail, 1-part

Package
· Micro-profiled operator rail, 2-part
· Rail connector
· Mounting material

Function/Application
· To transmit the power from the operator system to the door
· Micro-profiled operator rail for the operator systems Comfort 211 (only SK 11 and SK 12), 220.2, 250.2, 250.2 speed, 252.2 and 257
· The rail length depends on the door height and on the door brand

Function/Application
· To transmit the power from the operator system to the door
· Micro-profiled operator rail for the operator systems Comfort 211 (only SK 11 and SK 12), 220.2, 250.2, 250.2 speed, 252.2 and 257
· The rail length depends on the door height and on the door brand

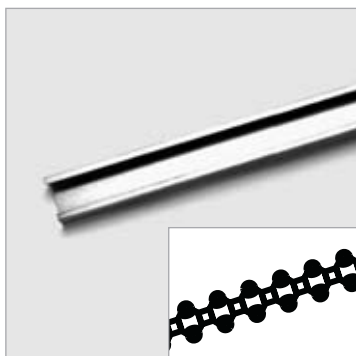

NEW

Ball rope, 1-part-version (0,8 mm)

Article	Article no.	Price each
ST 11, 1-part	84 420	
Measurements (L)	3.080 mm	
Length of travel	2.475 mm	
Packing length	3.140 mm	
Weight (total)	4,4 kg	

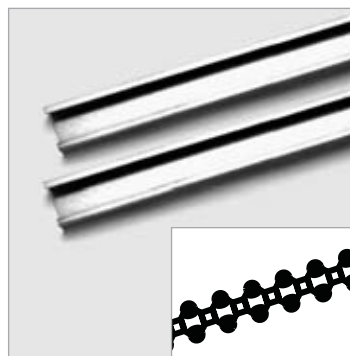

NEW

Ball rope, 2-part-version (0,8 mm)

Article	Article no.	Price each
ST 11, 2-part	84 421	
Measurements (L)	3.080 mm	
Length of travel	2.475 mm	
Packing length	1.600 mm	
Weight (total)	5,1 kg	

Article	Article no.	Price each
ST 12, 1-part	84 422	
Measurements (L)	3.330 mm	
Length of travel	2.725 mm	
Packing length	3.380 mm	
Weight (total)	4,7 kg	

Article	Article no.	Price each
ST 12, 2-part	84 423	
Measurements (L)	3.330 mm	
Length of travel	2.725 mm	
Packing length	1.725 mm	
Weight (total)	5,4 kg	

Package
· Micro-profiled operator rail, 1-part

Package
· Micro-profiled operator rail, 1-part
· Rail connector
· Mounting material

Function/Application
· To transmit the power from the operator system to the door
· Micro-profiled operator rail for the operator systems Comfort 211 and 220.2
· The rail length depends on the door height and on the door brand

Function/Application
· To transmit the power from the operator system to the door
· Micro-profiled operator rail for the operator systems Comfort 211 and 220.2
· The rail length depends on the door height and the door band

Operator rails

1.12 Comfort 211, 220.2, 250.2, 250.2 speed, 252.2, 257

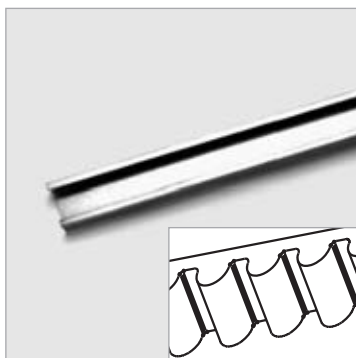

NEW

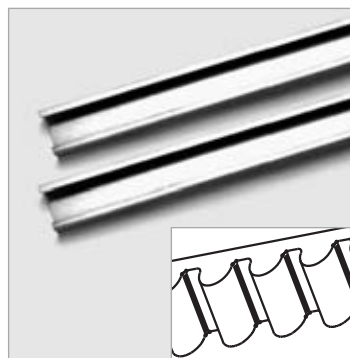

NEW

Toothed drive belt, 1-part version (0,8 mm)

Article	Article no.	Price each
SZ 11, 1-part	83 725	
Measurements (L)	3.080 mm	
Length of travel	2.475 mm	
Packing length	3.140 mm	
Weight (total)	4,7 kg	

Toothed drive belt, 2-part version (0,8 mm)

Article	Article no.	Price each
SZ 11, 2-part	83 737	
Measurements (L)	3.080 mm	
Length of travel	2.475 mm	
Packing length	1.600 mm	
Weight (total)	5,4 kg	

Article	Article no.	Price each
SZ 12, 1-part	83 726	
Measurements (L)	3.330 mm	
Length of travel	2.725 mm	
Packing length	3.380 mm	
Weight	5,0 kg	

Article	Article no.	Price each
SZ 12, 2-part	83 738	
Measurements (L)	3.330 mm	
Length of travel	2.725 mm	
Packing length	1.725 mm	
Weight (total)	5,9 kg	

Article	Article no.	Price each
SZ 13, 1-part	83727	
Measurements (L)	4.090 mm	
Length of travel	3.485 mm	
Packing length	4.140 mm	
Weight (total)	6,2 kg	

Article	Article no.	Price each
SZ 13, 2-part	83 739	
Measurements (L)	4.090 mm	
Length of travel	3.485 mm	
Packing length	2.100 mm	
Weight (total)	7,0 kg	

Package
· Micro-profiled operator rail, 1-part

Package
· Micro-profiled operator rail, 2-part
· Rail connector
· Mounting material

Function/Application
· To transmit the power from the operator system to the door
· Micro-profiled operator rail for the operator systems Comfort 211 (only SZ 11 and SZ 12), 220.2, 250.2, 250.2 speed, 252.2 and 257
· The rail length depends on the door height and the door brand

Function/Application
· To transmit the power from the operator system to the door
· Micro-profiled operator rail for the operator systems Comfort 211 (only SZ 11 and SZ 12), 220.2, 250.2, 250.2 speed, 252.2 and 257
· The rail length depends on the door height and the door brand

Operator rails

Comfort 211, 220.2, 250.2, 250.2 speed, 252.2, 257

1.13

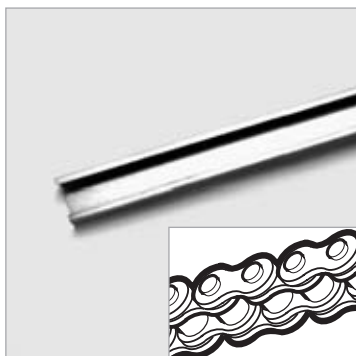

NEW

Roller chain, 1-part version (1,2 mm)

Article	Article no.	Price each
SK S 11, 1-part	86 318	
Measurements (L)	3.080 mm	
Length of travel	2.475 mm	
Packing length	3.140 mm	
Weight (total)	5,9 kg	

Article	Article no.	Price each
SK S 12, 1-part	86 319	
Measurements (L)	3.330 mm	
Length of travel	2.725 mm	
Packing length	3.380 mm	
Weight	6,3 kg	

Article	Article no.	Price each
SK S 13, 1-part	86 320	
Measurements (L)	4.090 mm	
Length of travel	3.485 mm	
Packing length	4.140 mm	
Weight (total)	8,2 kg	

Package
· Micro-profiled operator rail, 1-part

Function/Application
· To transmit the power from the operator system to the door
· Micro-profiled operator rail for the operator systems Comfort 250.2, 250.2 speed, 252.2 and 257
· For heavy garage doors as well as underground and collective garages

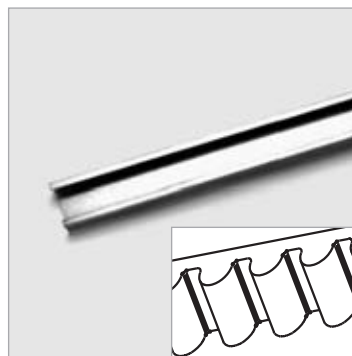

NEW

Toothed drive belt, 1-part version (1,2 mm)

Article	Article no.	Price each
SZ S 11, 1-part	86 315	
Measurements (L)	3.080 mm	
Length of travel	2.475 mm	
Packing length	3.140 mm	
Weight (total)	4,7 kg	

Article	Article no.	Price each
SZ S 12, 1-part	86 316	
Measurements (L)	3.330 mm	
Length of travel	2.725 mm	
Packing length	3.380 mm	
Weight (total)	5,0 kg	

Article	Article no.	Price each
SZ S 13, 1-part	86 317	
Measurements (L)	4.090 mm	
Length of travel	3.485 mm	
Packing length	4.140 mm	
Weight (total)	6,2 kg	

Package
· Micro-profiled operator rail, 1-part

Function/Application
· To transmit the power from the operator system to the door
· Micro-profiled operator rail for the operator systems Comfort 250.2, 250.2 speed, 252.2 and 257
· For heavy garage doors as well as underground and collective garages