

Comfort 211 accu

Operator system for garage doors



[E O S] EASY OPERATING SYSTEM

Comfort 211 accu

Article	Article no.
Motor unit Comfort 211 battery-powered	79 195

Package

- Motor unit Comfort 211 accu, pre-cabled
- Rechargeable battery
- Plug-in charger
- Multibit remote control 433 MHz
- Digital 302 Mini hand transmitter, 2-channel
- Universal mounting kit for up-and-over doors and sectional doors

+

Electrical details

Nominal voltage	24 V DC
Rechargeable battery capacity	7 Ah
Power consumption stand-by	1,5 mA
Power input in operation	0,12 KW
Power input stand-by	0,036 W
Operation mode (duty cycle)	KB 2 min.
Control voltage	24 V DC
Protection category motor unit	IP 20
Protection class	II

Mechanical details

Push and pull force	400 N
Door travel speed	120 mm/sec.
Opening time (door-specific) approx.	18 sec.

General details

Measurements	(Motor unit) 277 x 137 x 160 mm (Accumulator unit) 260 x 215 x 75 mm
Weight	(Motor unit) 2,3 kg (Accumulator unit) 5,5 kg
Range of temperature	-20°C to +60°C
Illuminant	LED

Function

- Economy mode
- Reference point technique
- Electronic travel cut-out
- Soft start/soft stop
- Push-open security device
- Anti-blocking device
- Excess travel stop
- Release from inside
- Connection for pushbuttons, code keypads and key switches
- Automatic cut-out 'Open' and 'Close' separately programmable
- Door travel speed programmable
- Soft run position 'Open' and 'Close' separately programmable
- Soft run travel speed 'Open' and 'Close' separately programmable
- Connection potential-free limit switch information
- Error message
- Reset function

Application

- Operator system for garage doors - private use
- For up-and-over doors up to a door width of 3.000 mm and a door weight of 75 kg
- For single-walled sectional doors up to a door width of 3.500 mm and a door weight of 75 kg
- For double-walled sectional doors up to a door width of 2.500 mm and a door weight of 75 kg
- For retractable up-and-over doors and canopy doors up to a door width of 3.000 mm, a door height of 2.250 mm and a door weight of 75 kg
- For maximum 2 parking lots or maximum 6 operations per day
- Service life at 4 cycles per day
 - approx. 60 days at an ambient temperature of 20° C
 - approx. 40 days at an ambient temperature of 0° C
 - approx. 30 days at an ambient temperature of -20° C
- For operator rails with roller chain, toothed drive belt or ball rope

Comfort 211 solar

Operator system for garage doors



[E O S] EASY OPERATING SYSTEM

Comfort 211 solar

Article	Article no.
Motor unit Comfort 211 solar	79 241

Package

- Motor unit Comfort 211 solar, pre-cabled
- Rechargeable battery
- Plug-in charger
- Solar module
- Charge regulator
- Multi-bit remote control, 433 MHz
- Digital 302 Mini hand transmitter, 2-channel
- Universal mounting kit for up-and-over doors and sectional doors

Electrical details

Nominal voltage	24 V DC
Rechargeable battery capacity	7 Ah
Power consumption stand-by	1,5 mA
Power input in operation	0,12 KW
Power input stand-by	0,036 W
Operation mode (duty cycle)	KB 2 min.
Control voltage	24 V DC
Protection category motor unit	IP 20
Protection class	II

Mechanical details

Push and pull force	400 N
Door travel speed	120 mm/sec.
Opening time (door-specific) approx.	18 sec.

General details

Measurements	(Motor unit) 277 x 137 x 160 mm (Accumulator unit) 260 x 215 x 75 mm
Weight	(Motor unit) 2,3 kg (Accumulator unit) 5,5 kg (Solar module) 6,0 kg
Range of temperature	-20°C to +60°C
Illuminant	LED

Function

- Economy mode
- Reference point technique
- Electronic travel cut-out
- Soft start/soft stop
- Push-open security device
- Anti-blocking device
- Excess travel stop
- Release from inside
- Connection for pushbuttons, code keypads and key switches
- Automatic cut-out 'Open' and 'Close' separately programmable
- Door travel speed programmable
- Soft run position 'Open' and 'Close' separately programmable
- Soft run travel speed 'Open' and 'Close' separately programmable
- Connection potential-free limit switch information
- Error message
- Reset function

Application

- Operator system for garage doors - private use
- For up-and-over doors with a door width of up to 3.000 mm and a door weight of 75 kg
- For single-walled sectional doors up to a door width of 3.500 mm and a door weight of 75 kg
- For double-walled sectional doors up to a door width of 2.500 mm and a door weight of 75 kg
- For retractable up-and-over doors and canopy doors up to a door width of 3.000 mm, a door height of 2.250 mm and a door weight of 75 kg
- For maximum 3 parking lots or maximum 6 operations per day
- For operator rails with roller chain, toothed drive belt or ball rope

Operator rails

Comfort 211, 220, 250, 250.2 speed, 252, 257

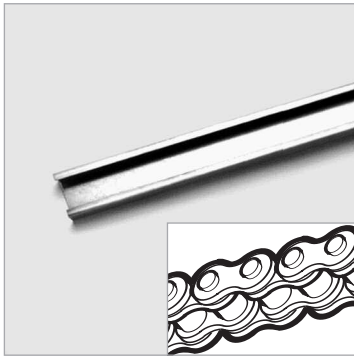

Roller chain, 1-part version

Article	Article no.	Price each
SK 11-L, 1-part	83 772	
Measurements (L)	3.080 mm	
Length of travel	2.475 mm	
Packing length	3.140 mm	
Weight	5,9 kg	

Article	Article no.	Price each
SK 12-L, 1-part	83 773	
Measurements (L)	3.330 mm	
Length of travel	2.725 mm	
Packing length	3.380 mm	
Weight	6,3 kg	

Article	Article no.	Price each
SK 13, 1-part	83 774	
Measurements (L)	4.090 mm	
Length of travel	3.485 mm	
Packing length	4.140 mm	
Weight	8,2 kg	

Package
· Micro-profiled operator rail, 1-part

Function/application
· To transmit the power from the operator system to the door
· Micro-profiled operator rail for the operator systems Comfort 211 (only SK 11-L and SK 12-L), 220, 250, 250.2 speed, 252 and 257
· The rail length depends on the door height and on the door brand

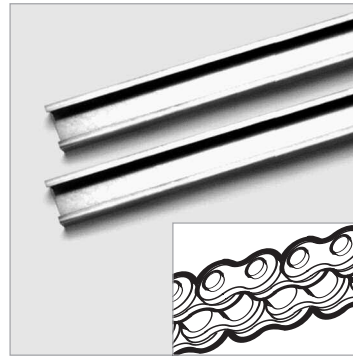

Roller chain, 2-part version

Article	Article no.	Price each
SK 11-L, 2-part	83 789	
Measurements (L)	3.080 mm	
Length of travel	2.475 mm	
Packing length	1.600 mm	
Weight	6,8 kg	

Article	Article no.	Price each
SK 12-L, 2-part	83 790	
Measurements (L)	3.330 mm	
Length of travel	2.725 mm	
Packing length	1.725 mm	
Weight	7,2 kg	

Article	Article no.	Price each
SK 13, 2-part	83 791	
Measurements (L)	4.090 mm	
Length of travel	3.485 mm	
Packing length	2.100 mm	
Weight	8,8 kg	

Package
· Micro-profiled operator rail, 2-part
· Rail connector
· Mounting material

Function/application
· To transmit the power from the operator system to the door
· Micro-profiled operator rail for the operator systems Comfort 211 (only SK 11-L and SK 12-L), 220, 250, 250.2 speed, 252 and 257
· The rail length depends on the door height and on the door brand

Operator rails

Comfort 211, 220

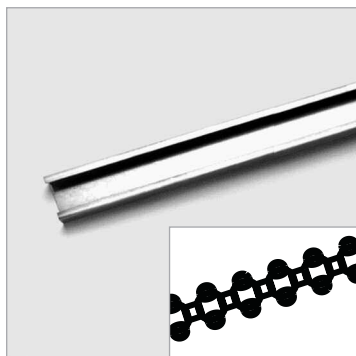

Ball rope, 1-part version

Article	Article no.	Price each
ST 11-L, 1-part	84 420	
Measurements (L)	3.080 mm	
Length of travel	2.475 mm	
Packing length	3.140 mm	
Weight	4,4 kg	

Article	Article no.	Price each
ST 12-L, 1-part	84 422	
Measurements (L)	3.330 mm	
Length of travel	2.725 mm	
Packing length	3.380 mm	
Weight	4,7 kg	

Package

- Micro-profiled operator rail, 1-part

Function/application

- To transmit the power from the operator system to the door
- Micro-profiled operator rail for the operator systems Comfort 211 and 220
- The rail length depends on the door height and on the door brand

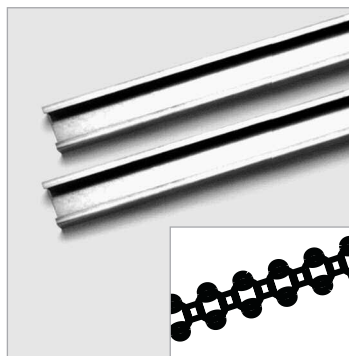

Ball rope, 2-part version

Article	Article no.	Price each
ST 11, 2-part	84 421	
Measurements (L)	3.080 mm	
Length of travel	2.475 mm	
Packing length	1.600 mm	
Weight	5,1 kg	

Article	Article no.	Price each
ST 12-L, 2-part	84 423	
Measurements (L)	3.330 mm	
Length of travel	2.725 mm	
Packing length	1.725 mm	
Weight	5,4 kg	

Package

- Micro-profiled operator rail, 2-part
- Rail connector
- Mounting material

Function/application

- To transmit the power from the operator system to the door
- Micro-profiled operator rail for the operator systems Comfort 211 and 220
- The rail length depends on the door height and on the door brand

Operator rails

Comfort 211, 220, 250, 250.2 speed, 252, 257

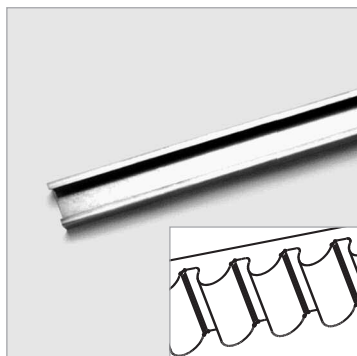

Toothed drive belt, 1-part version

Article	Article no.	Price each
SZ 11-L, 1-part	83 725	
Measurements (L)	3.080 mm	
Length of travel	2.475 mm	
Packing length	3.140 mm	
Weight	4,7 kg	

Article	Article no.	Price each
SZ 12-L, 1-part	83 726	
Measurements (L)	3.330 mm	
Length of travel	2.725 mm	
Packing length	3.380 mm	
Weight	5,0 kg	

Article	Article no.	Price each
SZ 13, 1-part	83 727	
Measurements (L)	4.090 mm	
Length of travel	3.485 mm	
Packing length	4.140 mm	
Weight	6,2 kg	

Package

- Micro-profiled operator rail, 1-part

Function/application

- To transmit the power from the operator system to the door
- Micro-profiled operator rail for the operator systems Comfort 211 (only SZ 11-L and SZ 12-L), 220, 250, 250.2 speed, 252 and 257
- The rail length depends on the door height and on the door brand

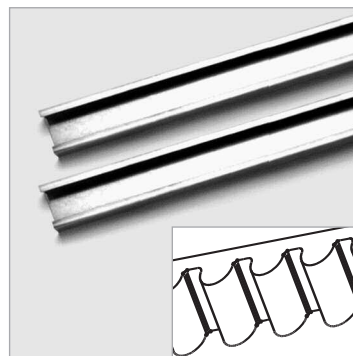

Toothed drive belt, 2-part version

Article	Article no.	Price each
SZ 11-L, 2-part	83 737	
Measurements (L)	3.080 mm	
Length of travel	2.475 mm	
Packing length	1.600 mm	
Weight	5,4 kg	

Article	Article no.	Price each
SZ 12-L, 2-part	83 738	
Measurements (L)	3.330 mm	
Length of travel	2.725 mm	
Packing length	1.725 mm	
Weight	5,9 kg	

Article	Article no.	Price each
SZ 13, 2-part	83 739	
Measurements (L)	4.090 mm	
Length of travel	3.485 mm	
Packing length	2.100 mm	
Weight	7,0 kg	

Package

- Micro-profiled operator rail, 2-part
- Rail connector
- Mounting material

Function/application

- To transmit the power from the operator system to the door
- Micro-profiled operator rail for the operator systems Comfort 211 (only SZ 11-L and SZ 12-L), 220, 250, 250.2 speed, 252 and 257
- The rail length depends on the door height and on the door brand