

Comfort 850 S, 851 S

Operator systems for sliding gates



FULL SERVICE



OPERATOR SYSTEMS
FOR GARAGE DOORS



OPERATOR SYSTEMS
FOR SECTIONAL DOORS



OPERATOR SYSTEMS
FOR SLIDING GATES



OPERATOR SYSTEMS
FOR HINGED GATES



OPERATOR SYSTEMS
FOR ROLLER SHUTTERS



PARC BARRIER
SYSTEMS



ELECTRONIC
CONTROL UNITS



PRODUCT SERVICE



ACCESSORIES



Energy saving operator systems for sliding gates in an elegant aluminium housing up to maximum gate width of 8.000 mm and maximum gate weight of 800 kg

NEW

- Effective power saving technique
- Ultra-modern DC technology
- New safety technique by means of the innovative microprocessor
- Certificates according to EN 13241-1
- No active main **and** second closing edge safety device required
- Drive cog adjustable in height up to maximum 20 mm
- Multi-functional control unit Control x.80
- Standard with 4-channel mini hand transmitter

Marantec

Door operators ► automatically the best choice

Technical data operator systems Comfort 850 S, 851

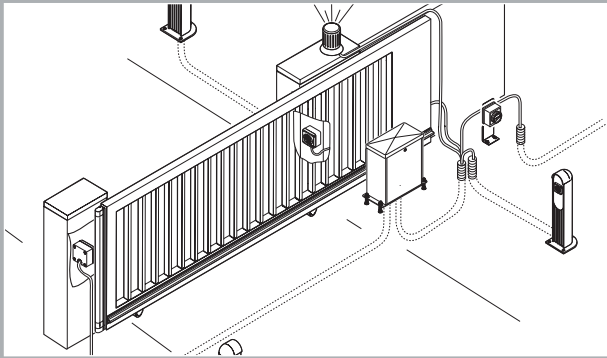

Electrical data	850 S	851 S	
Nominal voltage	230	230	V
Nominal frequency	50	50	Hz
Current input	1	1	A
Power consumption in operation	0,2	0,2	KW
Power consumption stand-by	< 4	< 4	W
Operating mode (duty cycle)	KB 5	KB 5	min.
Control voltage	24	24	V DC
Protection category motor unit	IP 44	IP 44	
Protection class	II	II	

Mechanical data	850 S	851 S	
Push and pull force	400	800	N
Travel speed	180	180	mm/sec.
Opening time (door specific) approx.	22	22	sec.

General data	850 S	851 S	
Measurements motor unit	330x335x 182		mm
Weight	12,5	14,5	kg
Range of temperature	- 20 to + 60		°C
Certification base	EN 292-1	EN 60335-1	
	EN 61000-6-2	EN 60335-2-103	
	EN 61000-6-3	EN 12445	
	EN 55014	EN 12453	
	EN 61000-3-2	EN 300220-1	
	EN 61000-3-3	EN 301489-3	
	ETS	300683	

Package

Motor unit Comfort 850 S or 851 S with integrated electronical control unit Control x.80
 Mounting plate and pre-assembled drive cog, Modul 4
 Digital 304 Mini hand transmitter, 4-channel, 868 MHz
 Release key
 Heavy-duty dowel set

Features / safety functions

Reference point technique	x
Soft start / soft stop	x
Automatic cut-out OPEN and CLOSE, separately programmable	x
Anti-blocking device	x
Excess travel stop	x
Automatic timer function	x
Electronic travel cut-out	x
Release	x
Economy mode	x
Connection for push buttons, code buttons and key switches	x
Connection possibility for actuation of premises lighting, 3 minutes	x
Part opening programmable	x
Connection for potential-free limit switch information	x
Error message	x
Reset function	x
Travel speed programmable	x
Lockable and removable profile	x
Drive cog, adjustable in height up to maximum 20 mm	x
Soft run position OPEN and CLOSE, separately programmable	x
Soft run travel speed OPEN and CLOSE, separately programmable	x
Retrofit kit potential-free signal relay for: Signal light, wipe impulse, 3-minutes light, limit switch information, error message	x

Accessories

Multibit remote control	x
Separate module aerial, 868 MHz, IP 65	x
Signal light	x
Closing edge safety device	x
Photocell, 2-wire-technique	x
Transponder systems	x
Key switches (pre-assembled)	x
Code keypads (pre-assembled with cables or RC)	x
Rack segments	x
Induction loop	x
Inductive signal transmission system	x
Gate bottom seal	x
Release from outside	x



Plastic toothed rack segments

Special 441	Modul 4 in aluminium cover profile
Special 432	Modul 4 in steel cover profile



Plastic toothed rack

Special 471	Modul 4 with steel core
--------------------	----------------------------



Marantec Antriebs- und Steuerungstechnik GmbH & Co. KG
 Remser Brook 11 · 33428 Marienfeld · Germany
 Tel. +49 52 47 7 05-0 · Fax +49 52 47 7 05-284

Marantec

Door operators ► automatically the best choice

www.marantec.com