

Dynamic 720

Operator system for Heavy Sliding Gates



FULL SERVICE



OPERATOR SYSTEMS FOR GARAGE DOORS



OPERATOR SYSTEMS FOR SECTIONAL DOORS



OPERATOR SYSTEMS FOR SLIDING GATES



OPERATOR SYSTEMS FOR HINGED GATES



OPERATOR SYSTEMS FOR ROLLER SHUTTERS



PARC BARRIER SYSTEMS



ELECTRONIC CONTROL UNITS



PRODUCT SERVICE



ACCESSORIES

Dynamic 720 is the innovative operator system for heavy sliding gates as yard entrances mainly for industrial use, with a maximum gate weight of 1.300 kg and/or a maximum gate width of 14 m. It fulfils all standards and legal regulations with regard to automated sliding gates.

The Dynamic 720 is equipped with our up-to-date frequency transformer technology, which reduces wear and tear of the gate in an optimal way due to the soft start and soft stop function, as well with part openings.

Marantec

Door operators ► automatically the best choice

Technical data operator system Dynamic 720

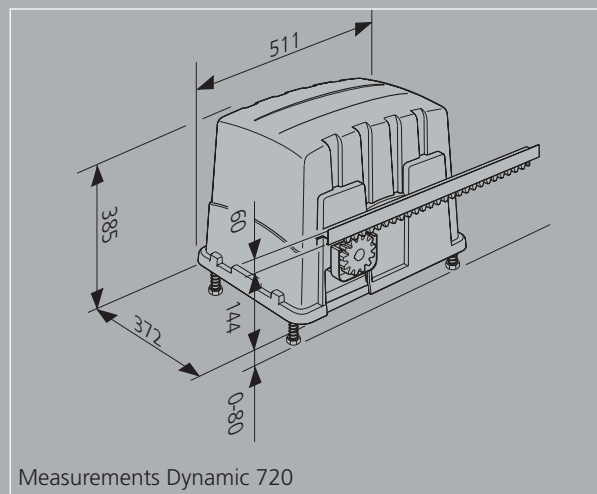
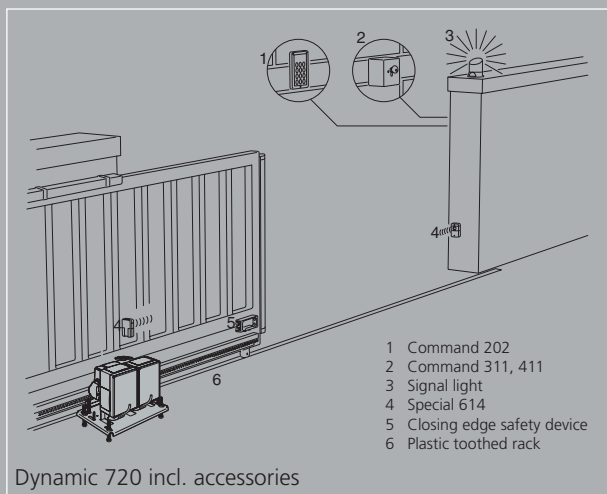

Electrical Data		
Nominal voltage	230	V
Nominal frequency	50	Hz
Current input	max. 6,3	A
Power consumption in operation	0,75	KW
Duty cycle	40	%
Control voltage	24	V DC
Protection category Motor unit/Control unit	IP 65	

Mechanical Data		
Push and pull force	2000	N
Door travel speed	170	mm/sec.

General Data			
Measurements Motor unit	372 x 385 x 511	mm	
Weight	30,0	kg	
Range of temperature	-20 to +60	°C	
Certification EN	12453	EN	12445
base	EN 292-1	EN	61000-3
	EN 50082-1	ZH	1/494 April 89
	EN 60335-1	VDE	0700-part 238

Supply Package	
Compact motor unit with frequency transformer technology	
Bottom plate with positioning template for foundation and spur gear 13 Z Modul 6	
Comfort control unit Control 145 FU-S	
Second control unit housing to install accessories and/or safety devices	
Lockable operator cover	

Plastic toothed rack segments	
Special 433	Module 6 in aluminium cover

Features / Safety Functions	
Frequency transformer technique	x
Reference point technique	x
Soft start/soft stop, as well with part openings	x
Automatic cut-out	x
Anti-blocking device	x
Excess travel stop	x
Automatic timer function	x
Electronic travel cut-out	x
Emergency release	x
Signal light connection	x
Connection for push buttons, code buttons and key switches	x
Error message	x
Motor with thermal overload protection	x
Programmable soft run	x
Programmable part openings	x
Programmable speed	x
Lockable operator cover	x

Accessories	
Multibit remote control	x
Separate module aerial, 868 MHz, IP 65	x
Signal light	x
Closing edge safety device	x
Inductive signal transmission	x
Photocell	x
Transponder systems	x
Key switches (pre-assembled)	x
Code keypads (pre-assembled)	x
Push button	x
Main switch	x
Induction loop	x



Marantec Antriebs- und Steuerungstechnik GmbH & Co. KG
Remser Brook 11 · 33428 Marienfeld · Germany
Tel. +49 52 47 7 05-0 · Fax +49 52 47 7 05-284

Marantec
Door operators ► automatically the best choice

www.marantec.com